



Cleco Power LLC

ELECTRIC SERVICE

STANDARDS

January 2024

This Page Left Blank Intentionally

SUMMARY OF REVISIONS

CLECO POWER LLC

OCTOBER 2008

This document has been extensively revised from the August 2006 issue, particularly Section 7, Section 8, and the illustrations in Appendices II and III.

FEBRUARY 2009

The following Figures were revised: IV-11, IV-11A, IV-12, IV-12A, IV-13, IV-13A, IV-14, IV-14A.

NOVEMBER 2012

The following Sections were rewritten and/or modified: 7.19, 7.20, 8.3, 8.5, 8.10, 8.11, 8.14, 8.21, A4.3, A4.4, A4.5. The following Figures were revised for minor corrections: I-1, I-2, I-3, I-4, I-6, I-8, I-9, I-10, I-12, II-5, II-7, II-11, III-1, III-9, III-10, III-12, III-13. The following Figures were modified to clarify service type and Cleco part numbers: IV-1, IV-2, IV-3, IV-4, IV-5, IV-6, IV-7, IV-8. Minor formatting and labeling of the document's Sections were changed for consistency.

FEBRUARY 2015

Added Fig. II-14 Meter Access Platform for Raising of Existing Meters Only.
Revised Fig. IV-11A, 12A, 13A, and 14A to include conduit bend radius for primary and secondary conduits.

APRIL 2015

Revised Fig. III-1 General Service Pole: Upsized round wood pole to minimum Class 6, added wording regarding approval of timbers and guying.

Revised Fig. III-2 Dual-General Service Pole: Upsized round wood pole to minimum Class 6, added wording regarding approval of timbers and guying.

Revised Figs. I-11&12, II-13, III-14, and IV-3,4,9, & 10 to show the non-fused load break disconnect switch ahead of meter for 480V services.

Added Fig. V-1A Multiple Occupancy Structures-Underground with up to 6 Service Laterals-277/480V and Fig. V-3A Multiple Occupancy Structures-Overhead with up to 6 Service Laterals-277/480V.

The following Sections were modified: 7.20, 8.14, and A4. Modified wording to have customer provide and install a non-fused load break disconnect switch on the source side of the meter for 480V services.

Revised Table 8-1: Maximum Service Conductors Allowed. Changed number of conductors for 277/480V 6000A and 6300A breaker size to max of 16 conductors.

MAY 2015

Revised Section 7.9.1 (d)- 0-750V Secondary Conductors, Modified clearance over State Highways.

Revised Fig. II-8: Renamed to imply 0-750V Secondary Conductors, Modified clearance over State Highways.

July 2016

Revised Fig. IV-5 and IV-7 to include table of junction box terminators supplied by Cleco.

October 2017

Revised Section 8.14.2 480 Volt Load break Disconnect: Revised wording concerning parameters about the customer furnished disconnect switch.

Added New Fig. I-4A; Single-Phase OH 200A 3-Wire 240/480 Volts

Added New Fig. I-4B; Single-Phase UG 200A 3-Wire 240/480 Volts

Removed Fig. II-2; Was combined with Fig: II-3 in 2008 Revision but drawing wasn't removed.

Revised Fig. III-13 Padmount Transformer Site Details; Added wording clarifying drawing refers to both single phase and three phase padmount transformers.

Revised Fig. IV-11 & Fig. IV-11A; Combined with Fig. IV-12 & Fig. IV-12A to cover padmount transformers Up thru 2500KVA.

Removed Fig. IV-12 & Fig. IV-12A; Combined with Fig. IV-11 & Fig. IV-11A.

Revised Fig. IV-13 & Fig. IV-13A; Combined with Fig. IV-14 & Fig. IV-14A to cover padmount transformers Up thru 2500KVA.

Removed Fig. IV-14 & Fig. IV-14A; Combined with Fig. IV-13 & Fig. IV-13A.

November 2019

Revised Sections 7.20.1, 7.20.2, 8.10.1 Note, Appendix Sections A4.5.2(b) Note and A4.5.2(c) Note; Replaced the word "should" with the "shall".

Revised Section 8.5 to add reference note in the very last sentence.

Revised formatting on section 8.5.2.

Revised Fig. I-4A, I-4B, II-7, IV-1, IV-2, IV-3, IV-4, IV-5, IV-6, IV-7, IV-8, IV-9 & IV-10 to show new SAP numbers.

July 2020

Added Sections 7.5.1 and 7.5.2 to add requirements for services under a building.

Revised Sections 7.20.3 (h) and 7.20.4 (f) to remove note about possibly requiring the use of the Customer's telephone line to access the meter for reading and programming.

Revised Section 8.3.1 (h) to include commercial sockets to requirements for standard meter sockets.

Revised Section 8.6 to change minimum capacity amperes from 100 to 150 and making it a requirement, instead of a recommendation, for residential dwellings.

The following Figures were revised: I-1, I-2, I-3, I-4.

October 2020

Revised Drawing III-13, Padmount Transformer site Details

April 2022

Revised Drawing III-10, Clearance distance changes in not section.

Revised Drawing III-13, Clearance distance changes, concrete pad update, revision to types of wall.

January 2024

Revised Drawing I-11, Note.

Revised Drawing I-12, Note.

Sections relevant to the user's application should be studied carefully. Any questions regarding exceptions or clarifications should be directed to the local engineering division of Cleco Power.

TABLE OF CONTENTS

1. INTRODUCTION	5
2. GENERAL REQUIREMENTS FOR SERVICE	5
3. CONTACTING CLECO	6
4. ADVISORY SERVICE FOR CUSTOMERS	8
5. DEFINITIONS	8
5.1 GENERAL TERMS.....	8
5.2 ELECTRICAL TERMS	9
6. TYPE AND CLASSIFICATION OF ELECTRIC SERVICE AVAILABLE	10
6.1 GENERAL DESCRIPTION	10
6.2 STANDARD CLASSES OF SERVICE AVAILABLE	11
6.3 DETAILED INFORMATION ON RATES.....	11
6.4 TABLE - ELECTRIC SERVICE RATES.....	11
6.5 ALTERNATING CURRENT FURNISHED.....	11
6.6 CUSTOMER'S RESPONSIBILITY	11
6.7 TYPE AND NOMINAL VOLTAGE OF ELECTRIC SERVICE AVAILABLE.....	11
6.8 PRIMARY VOLTAGES AVAILABLE	11
7. COMPANY'S INSTALLATION	11
7.1 GENERAL DESCRIPTION	11
7.2 AVAILABILITY.....	11
7.3 CUSTOMER'S RESPONSIBILITY TOWARD THE COMPANY	11
7.4 VOLTAGE(S) AVAILABLE	11
7.5 LOCATION OF SERVICE.....	12
7.6 RIGHT-OF-WAY.....	12
7.7 RELOCATION.....	12
7.8 POINT OF ATTACHMENT	12
7.9 MINIMUM CLEARANCE.....	12
7.10 SERVICE MAST	13
7.11 LENGTH OF SERVICE DROP.....	13
7.12 ATTACHMENT OF SERVICE DROP	13
7.13 SAFETY OF CUSTOMER'S STRUCTURE.....	13
7.14 TEMPORARY SERVICE	13
7.15 MOBILE HOMES/MOBILE HOME PARKS	13
7.16 MARINAS.....	13
7.17 METER INSTALLATION	13
7.18 METER CONNECTION AND SEALS.....	13
7.19 MULTIPLE SERVICES TO ONE BUILDING.....	14
7.20 SERVICES TO MULTIPLE OCCUPANCY BUILDINGS	14
8. CUSTOMER'S INSTALLATION AND SERVICE EQUIPMENT	15
8.1 GENERAL	15
8.2 SERVICE ENTRANCE	15
8.3 METER SOCKET REQUIREMENTS	16
8.4 INSPECTION AND APPROVALS.....	17
8.5 LOCATION OF METERS	17
8.6 NUMBER AND SIZE OF SERVICE CONDUCTORS.....	18
8.7 GROUNDING OF SERVICE ENTRANCE EQUIPMENT	20
8.8 SERVICE ENTRANCE FROM OVERHEAD SERVICE	21
8.9 CONDUIT RISER FOR OVERHEAD SERVICES.....	21
8.10 CONDUCTOR IN CONDUIT RISER FOR OVERHEAD SERVICE	22
8.11 SERVICE ENTRANCE MASTS	22

8.12	SERVICE TO MOBILE HOMES/MOBILE HOME PARKS/BOAT SLIPS/MARINAS.....	23
8.13	SERVICE ENTRANCE FROM UNDERGROUND SOURCE.....	23
8.14	DISCONNECTING MEANS FOR SERVICE LESS THAN 600 VOLTS.....	23
8.15	DISCONNECTING MEANS FOR SERVICE OVER 600 VOLTS.....	23
8.16	CUSTOMER'S UTILIZATION EQUIPMENT.....	24
8.17	MOTORS.....	24
8.18	MOTOR STARTING CURRENTS.....	25
8.19	MOTOR PROTECTION.....	26
8.20	CAPACITORS AND OTHER REACTIVE EQUIPMENT.....	27
8.21	ON SITE GENERATION.....	27
8.22	SURGE PROTECTION.....	27
8.23	PUBLIC SIGN CLEARANCE.....	27
8.24	MISUSE OR DAMAGE TO COMPANY'S FACILITIES.....	28
8.25	FOREIGN ATTACHMENTS TO COMPANY POLES.....	28
8.26	SERVICES LARGER THAN 400 AMPERES.....	28
A4:	REQUIREMENTS FOR SERVICES LARGER THAN 400 AMPERES	80
A4.1	GENERAL.....	80
A4.2	OVERHEAD SERVICES, 600 AMPERES.....	80
A4.3	OVERHEAD SERVICES, LARGER THAN 600 AMPERES.....	80
A4.4	UNDERGROUND SERVICES, 600 AMPERES:.....	80
A4.5	UNDERGROUND SERVICES LARGER THAN 600 AMPERES.....	81

FIGURES

FIGURE 1:	STATE MAP OF REGIONAL OFFICES.....	7
-----------	------------------------------------	---

TABLES

TABLE 3-1:	CLECO REGIONAL OFFICES.....	6
TABLE 8-1:	MAXIMUM SERVICE CONDUCTORS ALLOWED.....	19
TABLE 8-2:	GROUNDING ELECTRODE CONDUCTOR FOR AC SYSTEM.....	20
TABLE 8-3:	GROUNDING RACEWAY AND EQUIPMENT.....	21
TABLE 8-4:	MOTOR NOMINAL SUPPLY VOLTAGE.....	24
TABLE 8-5:	ALLOWABLE STARTING CURRENTS FOR SINGLE-PHASE MOTORS.....	25
TABLE 8-6:	ALLOWABLE STARTING CURRENTS FOR SINGLE-PHASE AIR CONDITIONERS.....	25
TABLE 8-7:	ALLOWABLE STARTING CURRENTS FOR THREE-PHASE MOTORS.....	26
TABLE 8-8:	AIR CONDITIONING AND HEAT PUMP EQUIPMENT RATINGS.....	26

APPENDIX I METER CONNECTIONS

FIG. I-1 SINGLE-PHASE OH 200A 3-WIRE 120/240 VOLTS..... 32
FIG. I-2 SINGLE-PHASE UG 200A 3-WIRE 120/240 VOLTS..... 33
FIG. I-3 SINGLE-PHASE OH 200A 3-WIRE 120/208 VOLTS..... 34
FIG. I-4 SINGLE-PHASE UG 200A 3-WIRE 120/208 VOLTS..... 35
FIG. I-4A SINGLE-PHASE OH 200A 3-WIRE 240/480 VOLTS..... 36
FIG. I-4B SINGLE-PHASE UG 200A 3-WIRE 240/480 VOLTS..... 37
FIG. I-5 SINGLE-PHASE OH 400A 3-WIRE 120/240 VOLTS..... 38
FIG. I-6 SINGLE-PHASE UG 400A 3-WIRE 120/240 VOLTS..... 39
FIG. I-7 THREE-PHASE 120/240 VOLTS..... 40
FIG. I-8 THREE-PHASE UG 400A 4-WIRE 120/240 VOLTS..... 41
FIG. I-9 THREE-PHASE OH 400A 4-WIRE 120/208 VOLTS..... 42
FIG. I-10 THREE-PHASE UG 400A 4-WIRE 120/208 VOLTS WYE..... 43
FIG. I-11 THREE-PHASE OH 400A 4-WIRE 277/480 VOLTS WYE..... 44
FIG. I-12 THREE-PHASE UG 400A 4-WIRE 277/480 VOLTS WYE..... 45

APPENDIX II OVERHEAD DRAWINGS

FIG. II-1 TYPICAL SERVICE LINE ARRANGEMENT 1 48
FIG. II-3 ILLUSTRATION OF CLEARANCES LESS THAN 600V PHASE-TO-GROUND 49
FIG. II-4 ILLUSTRATION OF SERVICE DROP CLEARANCE OVER TRAILER, ETC. 50
FIG. II-5 ILLUSTRATION OF SERVICE DROP CLEARANCE OVER BUILDINGS 51
FIG. II-6 TYPICAL OVERHEAD SERVICE INSTALLATION 52
FIG. II-7 TYPICAL OVERHEAD SERVICE MAST INSTALLATION 53
FIG. II-8 0-750V SECONDARY OH CLEARANCES..... 54
FIG. II-9 POINT OF CONNECTION DETAILS: NON-MAST CONNECTED SERVICES 55
FIG. II-10 CLECO APPROVED GROUND ROD..... 56
FIG. II-11 ILLUSTRATION OF TEMPORARY SERVICE, UNBRACED POLE..... 57
FIG. II-12 ILLUSTRATION OF TEMPORARY SERVICE, BRACED POLE 58
FIG. II-13 277/480 VOLT OVERHEAD SELF-CONTAINED INSTALLATION 59
FIG. II-14 METER ACCESS PLATFORM FOR RAISING OF EXISTING METERS ONLY 60

APPENDIX III MOBILE HOME & UNDERGROUND SERVICES

FIG. III-1 GENERAL SERVICE POLE..... 64
FIG. III-2 DUAL GENERAL SERVICE POLE..... 65
FIG. III-3 MULTIPLE GENERAL SERVICE POLE 66
FIG. III-4 MULTIPLE GENERAL URD SERVICE..... 67
FIG. III-5 TYPICAL MOBILE HOME SERVICE INSTALLATION..... 68
FIG. III-6 TYPICAL UNDERGROUND LINE ARRANGEMENT 69
FIG. III-7 OVERHEAD MOBILE HOME SERVICE..... 70
FIG. III-8 TYPICAL UG LINE ARRANGEMENT..... 71
FIG. III-9 SINGLE PHASE RESIDENTIAL UNDERGROUND SERVICE FROM OVERHEAD..... 72
FIG. III-10 SINGLE PHASE RESIDENTIAL UG SERVICE FROM PADMOUNT OR PEDESTAL 73
FIG. III-11 DETAIL OF UG LATERAL FOR RESIDENTIAL SERVICE..... 74
FIG. III-12 URD TEMPORARY SERVICE 75
FIG. III-13 PADMOUNT TRANSFORMER SITE DETAILS 76
FIG. III-14 277/480 VOLT UNDERGROUND SELF-CONTAINED INSTALLATION 77

APPENDIX IV REQUIREMENTS FOR SERVICES WITH MAIN LARGER THAN 400 AMPERES

A4 REQUIREMENTS FOR SERVICES LARGER THAN 400 AMPERES 80
A4.1 GENERAL 80
A4.2 OVERHEAD SERVICES, 600 AMPERES..... 80
A4.3 OVERHEAD SERVICES LARGER THAN 600 AMPERES 80
A4.4 UNDERGROUND SERVICES, 600 AMPERES 80
A4.5 UNDERGROUND SERVICES LARGER THAN 600 AMPERES 81
FIG. IV-1 TRANSOCKET-OH SERVICE 120/240, 120/208 VOLTS, 600 AMPS 84
FIG. IV-2 TRANSOCKET-UG SERVICE 120/240, 120/208 VOLTS, 600 AMPS 85
FIG. IV-3 TRANSOCKET OH SERVICE 277/480 VOLTS, 600 AMPS..... 86
FIG. IV-4 TRANSOCKET UG SERVICE 277/480 VOLTS, 600 AMPS..... 87
FIG. IV-5 CT OH SERVICE – INTERIOR DISCONNECT 120/208 VOLTS, LARGER THAN 600 AMPS 88
FIG. IV-6 T OH SERVICE – EXTERIOR DISCONNECT 120/208 VOLTS, LARGER THAN 600 AMPS 89
FIG. IV-7 CT UG SERVICE – INTERIOR DISCONNECT 120/208V, LARGER THAN 600 AMPS 90
FIG. IV-8 CT UG SERVICE – EXTERIOR DISCONNECT 120/208V, LARGER THAN 600 AMPS 91
FIG. IV-9 CT OH SERVICE 277/480 VOLTS, LARGER THAN 600 AMPS..... 92
FIG. IV-10 CT UG SERVICE 277/480 VOLTS, LARGER THAN 600 AMPS 93
FIG. IV-11 CONCRETE XFM PAD 13.2KV 3-PHASE UP THRU 2500KVA 94
FIG. IV-11A CONCRETE XFM PAD 13.2KV 3-PHASE UP THRU 2500KVA 95
FIG. IV-13 CONCRETE XFM PAD 35KV 3-PHASE UP THRU 2500KVA 96
FIG. IV-13A CONCRETE XFM PAD 35KV 3-PHASE UP THRU 2500KVA 97

APPENDIX V MULTIPLE OCCUPANCY STRUCTURES

FIG. V- 1 MULTIPLE OCCUPANCY : UG; UP TO 6 SERVICE LATERALS..... 100
FIG. V- 1A MULTIPLE OCCUPANCY : UG; UP TO 6 SERVICE LATERALS-277/480V 101
FIG. V- 2 MULTIPLE OCCUPANCY: UG UTILIZING METER CENTERS W/ MAINS GROUPED..... 102
FIG. V- 3 MULTIPLE OCCUPANCY : OH; UP TO 6 SERVICE LATERALS 103
FIG. V- 3A MULTIPLE OCCUPANCY : OH; UP TO 6 SERVICE LATERALS-277/480V..... 104
FIG. V- 4 MULTIPLE OCCUPANCY: OH UTILIZING METER CENTERS W/ MAINS GROUPED..... 105

APPENDIX VI LOAD INVENTORY FORMS

FORM 1: ELECTRICAL LOAD INVENTORY 109
FORM 2: MOTOR INVENTORY..... 111

ELECTRIC SERVICE STANDARDS

1. INTRODUCTION

The information and suggestions in the *Cleco Electric Service Standards (Service Standards)* are presented for the purpose of informing Customers, Architects, Builders, Contractors, Developers, Engineers, and others in the planning of electrical installations intended for connection to Cleco power lines. The information and data presented herein are intended to conform with and be supplementary to, applicable sections of the latest edition of the National Electrical Code (NEC), the National Electrical Safety Code (NESC), and with the applicable state, parish, and local regulations. Statements concerning the NEC refer to Customer owned facilities. This book is subject to extension and revision from time to time as new methods and improved facilities and equipment become available. These current procedures, practices, and requirements are adopted by Cleco to assure the most economical, safe, and satisfactory service to its Customers. Cleco Power, LLC (The Company) has representatives who will meet with the Customer and discuss any problem that may arise concerning the installation or use of Cleco's electric service. Questions regarding a specific Customer installation should be addressed to the local representative (refer to Section 3). Should questions regarding interpretation of the contents of this book arise, they should be addressed to Distribution Engineering Standards.

2. GENERAL REQUIREMENTS FOR SERVICE

To ensure promptness in receiving electrical services and to facilitate its preparation and installation, it is essential for the Customer or Contractor to consult the Company about any addition of equipment which is to be connected to the wiring system. Before any wiring or electrical equipment is purchased, the Company shall be consulted regarding availability and character of service, and location of the service drop, service entrance, and meter. The Customer will furnish the following information to the Company:

- (a) Exact location or premises where service is desired, including:
 1. Survey / Civil site plan
 2. Site plan with proposed construction indicated and desired location of electric service shown.
- (b) Character, manufacturer's rating, and amount of electrical load to be installed. (Refer to Cleco Electric Load information form in Appendix VI)
- (c) Type of service being requested (Caution - Note available voltages in Section 6 of this standard).
- (d) Number of motors by individual horsepower ratings and proposed starting equipment. If motor rating exceeds 20 horsepower or if the motor's voltage is 2400 V or greater, the type of starting, voltage rating, NEMA Starting Code, and frequency of starting will be required. Please note that for motors which exceed 20 hp, 120/240 Volts, 3-Phase, 4-Wire service is not available. (Refer to Appendix VI for suggested format of the above requested information)
- (e) General characteristics of machinery to be driven by motors.
- (f) Date electric service is needed.

Upon receipt of the above information, the Company will advise the Customer as promptly as possible regarding the availability of electric service. The wiring of the Customer's appliances shall be installed and maintained in accordance with the requirements of the latest editions of the National Electrical Code, the National Electrical Safety Code, and state, parish and local ordinances. The Company does not inspect wiring except for the protection of its service and equipment. The Company reserves the right to refuse to connect its service if it should come to the Company's attention that the Customer's installation is unsafe or if any material, equipment and/or the installation is below minimum standards as described herein. The Company will not be responsible in any way for any defect in the wiring or equipment of the Customer or for damages that may result from such defects. The Company (or Company's Contractor) shall make the connection between the Company's facilities and the Customer's installation. This, however, does not preclude the Customer's Contractor or Electrician from installing certain equipment furnished by the Company.

ELECTRIC SERVICE STANDARDS

3. CONTACTING CLECO

You can contact Cleco through our Customer Call Center at your convenience 24 hours a day, 365 days a year. The call center can be your single source for almost any help or information you need and can be reached toll-free by calling **(800) 622-6537**.

Call Center Specialists are knowledgeable about all Cleco services and are familiar with the entire service area. Their main function is to help Customers get the services and information they need and to help resolve any questions or problems that they may have.

Cleco maintains regional offices strategically located around the state, ready to help Customers who prefer to handle their business with the Company in person. Friendly Customer service representatives can assist in paying bills, connecting, disconnecting or transferring service; and almost any additional services or information needed. Regular office hours are 8:30 a.m. to 4:30 p. m., Monday through Friday. Figure 1 shows the approximate location of the regional offices on the Louisiana State map.

Cleco Regional Offices	
REGION	ADDRESS
Bunkie	401 Walnut Street
Covington	832 E. Boston Street Unit 17
Crowley	2105 N. Parkerson Ave. Suite B
DeRidder	820 N. Pine Street
Eunice	151 N. 4th Street
Franklin	815 N. W. Blvd.
Mandeville	2900 E. Causeway Approach
Mansfield	900 Washington Ave.
New Iberia	1015 Progress Street
Opelousas	369 E. Landry Street
Pineville	936 Main Street
Slidell	154 Florida Ave.
Ville Platte	515 West Lincoln

Table 3-1: Cleco Regional Offices

ELECTRIC SERVICE STANDARDS

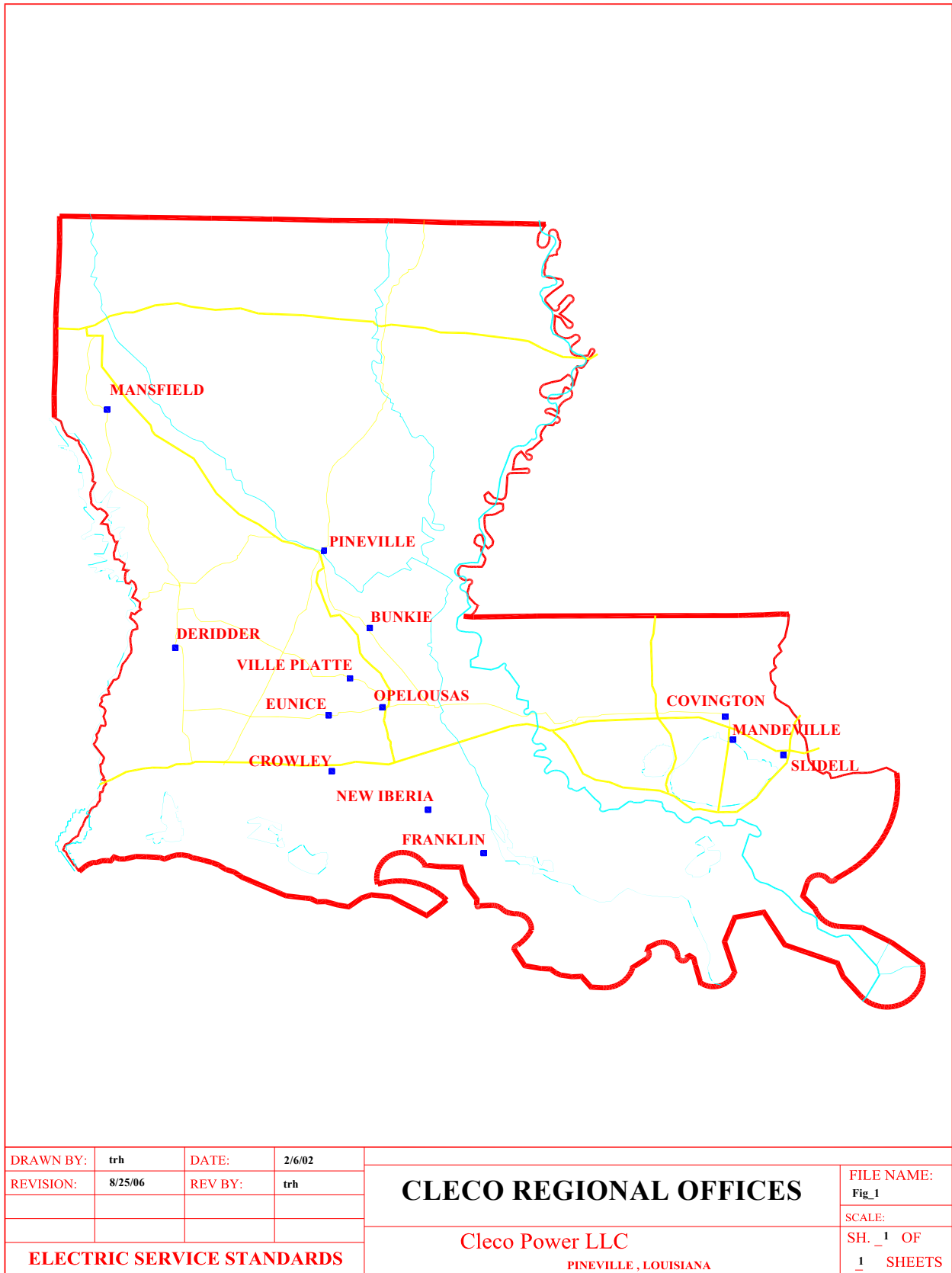

Figure I: State Map of Regional Offices

ELECTRIC SERVICE STANDARDS

4. ADVISORY SERVICE FOR CUSTOMERS

Cleco maintains a staff of highly qualified Customer Service Representatives to aid you in getting the most from your electric service through wise energy management. The Company endeavors to keep abreast of developments in lighting and power applications and other data which pertain to the most efficient use of electricity. Service assistance, with respect to lighting, wiring installations and efficient use of electricity in cooking, heating, air conditioning, and other electrical applications, is provided free of charge. Cleco also provides dedicated personnel to work with large commercial and industrial Customers. These representatives are available to provide assistance in meeting the special energy needs of Cleco's larger Customers. Contact information for Customer Service Representatives is available from Cleco's 24-hour call center at **(800) 622-6537**.

5. DEFINITIONS

This section includes a list of terms used in the body and appendices of the Service Standards. For terms not found in this list, consult the current editions of the NEC and/or the NESC. Some terms in this list will be duplicated in the NEC, but will have an expanded or more detailed definition than in the NEC. If there is a conflict between the definition in the Service Standards and the NEC, the Electric Service Standards shall be the ruling definition.

5.1 General Terms

5.1.1 Application, Agreement for Service: The Agreement between the Company and the Customer under which electric service is taken. It will comply with all Cleco standards, state, parish, and city ordinances.

5.1.2 Application, Agreement for Contract Power: A formal agreement contract between the Customer and Cleco, which will comply with the Company's standards.

5.1.3 Approved: The Customer's installation meets the requirements of the authority having jurisdiction (federal, state, parish, city, town agencies), and/or Cleco.

5.1.4 Authority or Governing Authority: The organization, office, or individual responsible for approving equipment, materials, an installation, or a procedure.

- (a) In public buildings or residential buildings of three (3) or more occupancies, the State Fire Marshall has jurisdiction.
- (b) In unincorporated areas and towns not having electrical inspectors, the Police Jury, Parish Council, Town Council, or Town Inspector is the governing authority if situation is not covered by (a) above.
- (c) In incorporated areas having an electrical inspector, the inspector shall be the governing authority.
- (d) Cleco's requirements will never be less stringent than those of the Governing Authority, but may, in some instances, be more stringent.

5.1.5 Company: Cleco Power LLC (Cleco)

5.1.6 Company Pole: Company owned poles and poles used by the Company under joint use agreements.

5.1.7 Contractor: One person or party contracting or doing business with the Company and/or Customer.

5.1.8 Customer: A person, individual, firm, partnership, association, corporation, organization, governmental agency, or other utility applying for service at one location.

5.1.9 Demand: The rate of use of service, during or averaged over a stated period

5.1.10 Grade: Ground Level

5.1.11 Grade, Finished: Ground Level after completion of all construction.

5.1.12 Inaccessible Areas: Those areas where maintenance, replacement, or repair would be difficult or objectionable to the Company or the Customer. (These areas will be designated by the Company.)

ELECTRIC SERVICE STANDARDS

- 5.1.13 Installation, Company:** In general, all wires, devices, and apparatus on the Company's side of the service point and such devices as may be installed on the Customer's side of the point of delivery for metering electric service (equipment furnished by Company).
- 5.1.14 Installation, Customer:** In general, all the wire, appliances, devices, or apparatus on the Customer's side of the service point, except the meters, metering devices, and accessories of the Company that may be located on the Customer's side of the point of delivery.
- 5.1.15 Meter:** The device, owned by the Company, used for measuring electrical power consumption. The most common type of meter on the Cleco system, the watt-hour meter, measures consumption in thousands of watts per hour (KWH).
- 5.1.16 Meter Socket (Meter Pan):** A device which provides support and means of electrical connection to a watt-hour meter. (Refer to Section 8.3)
- 5.1.17 Meter Socket, Combination Unit:** A unit divided into two compartments, one of which contains a meter socket. The second compartment consists of either a breaker panel or a generator transfer switch. (Refer to Section 8.3.2)
- 5.1.18 Meter Socket, Dual Use Unit:** A meter socket which is designed for use in an overhead or an underground installation. **Must be labeled for use as either Overhead or Underground and Underground Meter Sockets must have an approved tamperproof raceway for the Primary Conductor to pass through.**
Note: On the Cleco system, dual use units installed for underground service must be left side, side-wire design. (Refer to Section 8.3.1)
- 5.1.19 Meter Socket, Gang Operated:** A meter socket with two (2) to six (6) meter blocks which share a common source side bus within one cabinet.
- 5.1.20 Point of Service (Service Point):** The point of connection between the facilities of the Company and the Customer's wiring.
(a) Overhead Service: The point of connection of the Company's service drop conductors and the Customer's service entrance conductors at the weather head.
(b) Underground Service: The point of connection at either the source (Company) side of the meter socket or where applicable, at the source side of the main disconnect (on services of 277/480V or more than 6 meters) or at the connection point in the junction box.
- 5.1.21 Service:** The electric power and energy at a delivery point, whether or not actually used by the Customer, made available by the Company to the Customer under a "Service Agreement ".
- 5.1.22 Service, Class of:** Service intended to be rendered under a particular Rate Schedule, such as, Residential Service (RS), General Service (GS), and Large Power Services (LPS).
- 5.1.23 Service, Type of:** The electrical attributes of the service: number of phases, voltage, frequency, and transformer connections.
- 5.1.24 Shall:** Mandatory rules of this Standard are characterized by the use of the word "shall".
- 5.1.25 Should:** Advisory rules of this Standard Service Practice are characterized by the use of the word "should" and, as stated, are strongly recommended, but are not required.
- 5.1.26 Specifications:** Physical, mechanical, or electrical characteristics of a piece of equipment which must be met in order for the equipment to be installed on the Cleco system. Also, a set of procedures which must be followed in order to have service connected.

5.2 Electrical Terms

- 5.2.1 Ampere:** The unit of measurement of the rate of flow of electricity. One ampere is the unit of current produced in a circuit by one volt acting through a resistance of one ohm.

ELECTRIC SERVICE STANDARDS

- 5.2.2 BTU (British Thermal Unit):** The quantity of heat required to raise the temperature of one pound of water one degree Fahrenheit. Capacity of air conditioning, heating, or heat content of fuel, etc., is measured in BTU.
- 5.2.3 BTUH (British Thermal Unit per hour):** Is the rate of heat change - BTU per hour.
- 5.2.4 Current:** The movement or flow of electricity usually measured in amperes.
- 5.2.4.1 Effective Ground/Effectively Grounded:** Bonded to an effectively grounded neutral conductor or to a grounding system designed to minimize hazards to personnel and having resistances to ground low enough to permit prompt operation of circuit protective devices.
- 5.2.4.2 Effectively Grounded Neutral Conductor:** A conductor that is intentionally connected to the source transformer neutral directly or through an impedance to limit phase-to-ground fault current and has not less than four grounds in each 1.6km (1.0 mi) of line. The conductor shall be of sufficient size to carry the available fault current and permit prompt operation of circuit protective devices.
- 5.2.5 Energy:** The total work done as distinguished from the rate of doing work (power).
- 5.2.6 Hertz:** Means cycles per second. Cleco furnishes AC electric power at a frequency of 60 hertz.
- 5.2.7 Horsepower:** A unit of power equal to a rate of 33,000 foot pounds of work per minute. Motors are generally rated in horsepower to indicate the mechanical power they are designed to produce. One horsepower = 746 watts.
- 5.2.8 Kilowatt (KW):** 1,000 watts.
- 5.2.9 Kilowatt-Hour (KWH):** 1,000 watt-hours.
- 5.2.10 Kilovolt-ampere (KVA):** 1,000 volt-amperes.
- 5.2.11 Neutral Conductor:** A neutral conductor carries only the unbalanced current from other conductors, as in the case of normally balanced circuits of three or more conductors. **Common Neutral conductors shall be effectively grounded.**
- 5.2.12 Ohms:** The unit of measurement of resistance to the flow of electrical current.
- 5.2.13 Phase or Number of Phases:** Designates characteristics of alternating current. Single phase is generally supplied to residences and small power Customers. Three-phase service is supplied to larger power Customers.
- 5.2.14 Power:** The time rate of doing work, generating, transferring, or using electric service, usually expressed in kilowatts (KW).
- 5.2.15 Rates:** The price per unit of electricity and the quantities to which they apply.
- 5.2.16 RKVA:** The product of the applied voltages and the magnetizing or charging current, divided by one thousand. Reactive power does no work, but must be supplied to magnetic equipment, such as motors. It is supplied by generators or capacitors.
- 5.2.17 Volt:** A unit of electrical pressure, potential, or electromotive force which if applied to a load of one ohm resistance will cause a current of one ampere to flow.
- 5.2.18 Watts:** The electrical unit of power or rate of doing work. $Watts = voltage \times amperage \times power\ factor$.

6. TYPE AND CLASSIFICATION OF ELECTRIC SERVICE AVAILABLE

6.1 General Description

This section describes the class of service offered to the Customer under the Company's rate schedules and the type of service available.

ELECTRIC SERVICE STANDARDS

6.2 Standard Classes of Service Available

A separate application or electric service agreement is required for each class of service furnished to each Customer. All services furnished under one application or service agreement will be delivered to one point and metered at or as near as possible to the service point.

6.3 Detailed Information on Rates

Detailed requirements for determining class of service and rates can be obtained from Cleco.

6.4 Table - Electric Service Rates

Detailed Rates and Rider Schedule can be obtained from Cleco.

6.5 Alternating Current Furnished

Cleco furnishes 60 hertz (cycles per second) alternating current, single and three-phase.

6.6 Customer's Responsibility

Customers should consult the Company as to the availability of services in the particular area before making wiring layouts, purchasing equipment, or making extensive changes in existing installations.

6.7 Type and Nominal Voltage of Electric Service Available

- (a) 120/240 Volt, Single-Phase, Three (3) wire, up to 600 amps.
- (b) 120/208 Volt, Two-Phase, Three (3) wire, Wye, up to 600 amps.
- (c) 120/208 Volt, Three-Phase, Four (4) wire, Wye, up to 2500 amps. Consult Cleco Engineering if a need for service larger than 2500 amperes is anticipated.
- (d) 277/480 Volt, Three-Phase, Four (4) wire, Wye, up to 4000 amps. . Consult Cleco Engineering if a need for service larger than 4000 amperes is anticipated.
- (e) 120/240 Volt, Combination Single-Phase and Three-Phase, Four (4) wire, Open Delta, up to 400 amps. Not recommended for service where any single motor is larger than twenty (20) horsepower. (Caution: Load increase for this type of service is not available.)

6.8 Primary Voltages Available

2,400/4,160Y; 7,620/13,200Y; 14,400/24,900Y; 19,920/34,500Y; 69,000; 138,000; 230,000.

Note: Above voltages are not available at all locations. Specific approval must be obtained in each case.

7 COMPANY'S INSTALLATION

7.1 General Description

The "Service" is the wiring system connecting the Company's distribution facilities with the Customer's service entrance and service equipment. The service may be installed overhead or underground.

7.2 Availability

The Company will offer the Customer a practical choice consistent with sound operation in the selection of the type of service best suited to his electrical requirements; however, there are areas in which certain voltages and/or three-phase facilities are not available and the cost of providing such facilities may not be economically feasible in relation to its value to the Customer or the revenues the Company can reasonably anticipate.

7.3 Customer's Responsibility Toward the Company

It is the Customer's responsibility to secure information from the Company pertaining to the types of service available at a particular location. This information should be obtained prior to completion of the plans for the Customer's electrical installation.

7.4 Voltage(s) Available

The type of service generally furnished as determined by size of load, nature of use and character of system are shown in Section 6. Not all voltages are available in all locations. Section 6.8 details the primary voltages which require special approval and may not be available at all locations. Any other type of service and voltage not set out in these paragraphs as the Company's standard voltage may be supplied only after specific approval is obtained from Industrial Services. Note: All voltages as stated are nominal values.

ELECTRIC SERVICE STANDARDS

7.5 Location of Service

7.5.1 General Requirements

The service may be installed overhead or underground depending on the Customer's desire and/or type of facilities available in the area of the premises to be served. The Company shall designate the location of the service point or attachment of the service to the Customer's premises, taking into consideration the shortest distance to the Company's distribution facilities, crossing adjacent property of others, and location of meter for reading and servicing. All service points shall be on land and mounted at an elevation sufficient to avoid inundation by normal tidal action or seasonal flooding. All electric service is required by the Company at one service point, except where a second separated service is required for exit or emergency lighting, fire pumps or other safety regulations, capacity requirements, buildings of larger areas, separate class of use, and for area lighting. Connection of the Company's service to the Customer's service entrance will not be made until the Customer's installation has been inspected and approved by the Company and by the authority having jurisdiction. Refer to Article 230 of the National Electrical Code.

7.5.2 Services Under a Building

The placement of the service should allow for future inspection, maintenance, or repair/replacement as needed. If placement of the service under a building or similar structure is required due to site limitations, the customer shall furnish, install, and retain ownership of the service, and shall be responsible for any repairs, replacements, or upgrades if ever necessary. Refer to Section 7.20.4 (a) thru (e) for the requirements which apply for routing a service under any building.

7.6 Right-of-Way

The Company shall be provided with proper easement (1) whenever facilities are installed on the Customer's premises, and (2) where facilities cross property of others.

7.7 Relocation

The Company will move or relocate the Company's facilities where practical to do so at the request of the Customer, provided that the Customer pays the cost of such relocation and provides new easements.

7.8 Point of Attachment

It is suggested that the point of attachment of the Company's service drop to the Customer's building should be at a minimum point of 12 feet above finished grade, and not more than a maximum point of 25 feet above finished grade (Refer to Appendix II.) Specific approval must be obtained for services greater than 600 volt.

7.9 Minimum Clearance

7.9.1 Overhead

(0 to 750 volts to ground) The point of attachment of the service drop (Insulated cabled supported on and cabled together with an effectively grounded bare messenger) shall be high enough to allow for the following minimum clearances: (Refer to Appendix II). Where these clearances as described below and in the NEC and NESC, cannot be met and/or maintained, service will not be provided. For voltages above 750 volts, phase to ground, consult the Company for clearances. For purposes of these standards, a truck is defined as any vehicle exceeding eight (8) feet in height from the ground to the highest point of the vehicle above ground.

- (a) 12 feet above finished grade, sidewalks, walkways for supply service drops
- (b) 16 feet above residential driveways, parking lots, and alleys (may be reduced to 15 feet in areas not subject to truck traffic)
- (c) 16 feet above roads, streets, and other areas subject to truck traffic
- (d) 20 feet above state highways (DOTD requirements may be greater in some cases)

7.9.2 Underground

- (a) Single phase residential service conduit will be buried with 24 inches of minimum cover. Refer to Appendix III, Figures III-9, III-10, and III-11 for details.
- (b) Padmount transformers must be sited with adequate clearance from buildings and other permanent structures such as fire hydrants. Refer to Appendix III, Figure III-10 for details on single phase transformers and Figure III-13 for details on three-phase transformers.

ELECTRIC SERVICE STANDARDS

7.10 Service Mast

Where the height of the building makes it impractical to attach the service drop at a point to provide for the necessary clearance above finished grade, a "service mast" or other approved extension shall be furnished and installed by the Customer to permit the point of attachment to be located at a proper height above ground. (Refer to Section 8.9 and Appendix II, Figure II-7 for additional information.)

7.11 Length of Service Drop

The length of the service drop from the Company's facilities to the first point of attachment shall not exceed 125 feet, except where required in special cases with specific approval of the Company. The Customer may be required to bear the expense of any additional poles.

7.12 Attachment of Service Drop

The service drop will be attached to the building by means of suitable brackets furnished and usually installed by the Customer. On buildings of wood the Customer shall provide suitable reinforcement or backing to the trim or wall covering for secure mounting of attachment fittings and adequate anchorage of the service drop. On buildings constructed of masonry, the Customer shall provide the necessary fastenings or supports, spaced according to dimensions which the Company will supply, for mounting the service drop attachment fittings. The Company also makes attachments to temporary service poles per Section 7.14 and to Mobile Home service poles per Section 7.15.

7.13 Safety of Customer's Structure

The Customer is required to make available safe and adequate structures for the Company's service attachments. The Company will not be responsible for the condition of any Customer's building or structures to which service wires have been attached.

7.14 Temporary Service

The Company provides many types and classes of temporary service which may be available at the location for construction work. The Customer must provide adequate protective devices for all temporary service and must have a ground fault interrupter (Refer to Appendix II, Figures II-11, II-12, and II-13.)

7.15 Mobile Homes/Mobile Home Parks

Cleco will provide service to mobile homes and mobile home parks provided that the service entrance equipment is installed according to Appendix III. Mobile home parks should generally implement grouped meter installations. Service entrance equipment must conform to requirements of the NEC and/or local electrical ordinances (Refer to Appendix III, Figures III-1 through III-7.)

7.16 Marinas

Cleco will provide overhead and/or underground service to boat docks and marinas provided that the service entrance equipment is installed in conformance with the requirements of the NEC and/or local electrical ordinances. All service points shall be on land and mounted at an elevation sufficient to avoid inundation by normal tidal action or seasonal flooding. Generally, meter installations for marinas should be grouped (Refer to Appendix III Figure III-4.) Consideration shall also be made in routing overhead electrical wiring to avoid areas subject to traffic by sail boats or other craft employing booms, masts, antennas, etc.

7.17 Meter Installation

The metering equipment, while furnished by the Company, is usually installed on the Customer's premises as part of the service entrance equipment, and provisions must be made for it in the Customer's installation. The metering equipment provided by the Company consists of kilowatt-hour meters, demand meters, recording demand devices, metering transformers, relay and associated devices, coded meter cables, test blocks, and other equipment. The equipment supplied will depend on the requirements of the applicable rate schedule and the Company's standard practices. An appointment with a Cleco Representative can be obtained by calling, toll-free, **(800) 622-6537**. For Current Transformer (CT) metering, the Company will also supply the (CT) panel and (CT) meter enclosure.

7.18 Meter Connection and Seals

The Company shall install the meter and tamper-seal all meters and metering equipment. Any accessible wiring on the source side of the meter must be inspected by the Company and provided with means to be sealed, and/or locked with a Company seal and/or lock. Only a duly authorized person shall be permitted to break or replace a

ELECTRIC SERVICE STANDARDS

tamper-seal or to remove or change a meter or its connection or location. Violations shall be dealt with in accordance with the Company policies. Tampering with or damaging this assembly, breaking the tamper-seal, attaching any wire or the use of any method or device which may permit the flow of un-metered or unauthorized electricity is unlawful. Offenders will be prosecuted.

7.19 Multiple Services to One Building

Cleco may provide more than one service to a building if sufficient cause exists under the following conditions (contact Cleco at **(800) 622-6537**):

- (a) Service for fire pump.
- (b) Legally required standby service.
- (c) Where capacity requirements are greater than 2000 amperes at less than 600 volts is required or where capacity requirement exceed the limits defined in Section 6.7.
- (d) Where different characteristics such as voltages or phases are required.

Note: Each meter socket shall be permanently marked to identify the premise served.

7.19.1 Multiple Services to One Building – Exceptions: Cleco may also run more than one service to a building under the following exceptions provided special permission is granted in writing by the governing authority. **Note:** Cleco is not the governing authority.

- (a) Multi-occupancy buildings where there is no space for service equipment accessible to all occupants.
- (b) Where building is of such large area that it requires more than one service.
- (c) Where unusual capacity requirements exist.

Note: Each meter socket shall be permanently marked to identify the premise served.

7.19.2 Multiple Services to One Building – Markings: Where a building or structure is supplied by more than one service, or any combination of branch circuits, feeders, and services, a permanent plaque or directory shall be installed at each service disconnect location denoting all other services, feeders, and branch circuits supplying that building or structure and the area served by each.

7.20 Services to Multiple Occupancy Buildings

7.20.1 Multiple Occupancy Buildings - Overhead Service: The Company will provide the necessary service drop conductors to the service mast(s) of a factory designed meter center or separate but grouped service entrances for each occupancy, and will make the connection to the Customer's service entrance conductors. (Refer to Appendix II and/or III). Service entrance conductors shall contain no splices or taps from the service point to the Company side of the meter socket, except for 277/480V applications where a load break disconnect is required on the source side of each meter socket. Where a pull box has been allowed between the Company's service drop and the metering device, the pull box shall be sealable and/or lockable, per Section 7.18. All applications where multiple occupancies exist within a single building, the Customer is urged to utilize factory designed meter centers. The factory designed meter center (including commercial metering switchboards) shall utilize ringless, cold sequence design for any voltage application through 600 Volts.

Note: Each meter socket shall be permanently marked to identify the premise served.

7.20.2 Multiple Occupancy Buildings - Underground Service: The Company will provide the necessary service lateral conductors to a factory designed meter center or separate but grouped service entrances for each occupancy from the nearest underground electrical source, and the Customer shall make the connection to the Customer's service entrance equipment. The Company will generally provide an electrical distribution source in close proximity to the service entrances (Refer to Appendix II and/or III). Service entrance conductors shall contain no splices or taps from the service point to the Company side of the meter socket, except for 277/480V applications where a load break disconnect is required on the source side of each meter socket. Where a pull box has been allowed in the service lateral routing between the Company's source equipment and the service point, the pull box shall be sealable and/or lockable per Section 7.18. In all applications where multiple occupancies exist within a single building, the Customer is urged to utilize a factory designed meter center. The factory designed meter center (including commercial metering switchboards) shall utilize ringless, cold sequence design for any voltage application through 600 Volts.

Note: Each meter socket shall be permanently marked to identify the premise served.

7.20.3 Special High Density Multiple Occupancies With Underground Service: An interior "*Meter Equipment Room*" may be permissible due to the large number of service entrances required and external space limitations. These "*Meter Equipment Rooms*" are subject to the following additional requirements:

ELECTRIC SERVICE STANDARDS

- (a) The Company's Distribution Design Engineer must review the planned installation and be in concurrence with the necessity of the interior "*Meter Equipment Room*".
 - (b) The Customer shall obtain, in writing, specific permission for the "*Meter Equipment Room*" from the authority having jurisdiction.
 - (c) The Customer shall furnish, install, and retain ownership of the service lateral(s), the meter socket(s), and any other service entrance equipment. Further, the Customer shall warrant that the installed components meet or exceed the minimum requirements of all applicable building and fire codes. The Company shall furnish, install, and own the meter(s). Any service equipment on the source side of the meter shall have provisions for Company inspection and tamper sealing without impairing the operation of the equipment.
 - (d) The "*Meter Equipment Room*" shall be accessible to the Company at any and all times. External entry is required and shall be via a lock and key system (Lock Boxes are preferred). Internal entry shall not be reliant on contacting building managers and/or custodians to gain access to the "*Meter Equipment Room*".
 - (e) Lighting within the "*Meter Equipment Room*" shall be maintained at adequate levels such that the Company's meter technicians can work safely without the use of supplemental lighting.
 - (f) The "*Meter Equipment Room*" shall have and maintain adequate working space and shall be kept free of debris in order for safe operation of the metering equipment and other service entrance equipment. The "*Meter Equipment Room*" shall not be used for any purposes other than as an electrical equipment room. Use of the "*Meter Equipment Room*" for storage shall be prohibited.
 - (g) The Service Point shall be identified as the source end of the Service Lateral.
- Note:** Each meter socket shall be permanently marked to identify the premise served.

7.20.4 Special High Density Multiple Occupancies - Service Laterals under Building: The preferred placement of the service lateral(s) is outside the building(s) footprint. However, certain multiple occupancy buildings may be of such size or shape that it is impractical to route the service lateral(s) around the building perimeter to the external meter center. Routing of the service lateral(s) beneath the building(s) may be permissible with the following requirements:

- (a) The Company's Distribution Design Engineer must review the planned installation and be in concurrence with the necessity of service lateral(s) being placed beneath the building(s).
 - (b) The Customer shall obtain, in writing, specific permission for the service lateral(s) being placed beneath the building(s) from the authority having jurisdiction.
 - (c) The Customer shall furnish, install and retain ownership of the service lateral(s), the meter socket(s), and any other service entrance equipment. The Customer shall warrant that the installed components meet or exceed the minimum requirements of all applicable building and fire codes. The Company shall furnish, install, and own the meter(s). Any service equipment on the source side of the meter(s) shall have provisions for Company inspection and tamper sealing without impairing the operation of the equipment.
 - (d) The service lateral(s) shall be concrete encased at every point below the building foundation(s). Spare service lateral conduit is highly recommended.
 - (e) The Service Point shall be identified as the source end of the Service Lateral.
- Note:** Each meter socket shall be permanently marked to identify the premise served.

7.20.5 Multiple Occupancy Buildings - Vertical Distribution: The Company will not install, nor will it own or maintain, a vertical distribution system.

8. CUSTOMER'S INSTALLATION AND SERVICE EQUIPMENT

8.1 General

Information regarding availability and characteristics of service, location of service entrance, and point of delivery must be determined by consulting with Cleco when planning new installations, changes, remodeling, or increases of electrical load. An appointment with a Cleco Representative can be obtained by calling, toll-free, **(800) 622-6537**.

8.2 Service Entrance

The metering equipment is usually installed on the Customer's premise as part of the service entrance equipment and provisions must be made for it in the Customer's installation. The metering installation shall be at a location

ELECTRIC SERVICE STANDARDS

satisfactory to Cleco (Refer to Appendix III and/or IV). The Customer's service entrance installation shall consist of the meter socket, service entrance conductors, conduits, and service equipment. The meter, Current Transformer (CT) panel and CT meter enclosure (when needed), shall be furnished by and remain the property of Cleco.

8.3 Meter Socket Requirements

For self-contained metering installations, the Customer is responsible for providing a meter socket which conforms to Cleco's requirements as listed below.

8.3.1 Standard Meter Sockets: Standard self-contained meter socket units, i.e. units consisting of only a meter socket block assembly, shall conform to the following requirements. Underground service entrance equipment installation shall be planned such that the incoming service lateral conductors do not cross the service entrance conductors within the meter socket. Incoming service lateral conductors shall not be allowed to enter the meter socket directly below the meter position.

- (a) All exterior meter sockets shall be NEMA type 3R, ringless.
- (b) Meter sockets shall be visibly and permanently marked with the manufacturer's name and catalog number.
- (c) On the inside of the enclosure, a permanent sticker shall be affixed listing the electrical rating and acceptable conductor sizes.
- (d) All meter sockets shall meet the standards of the current editions of the American National Standards Institute (ANSI C12.7 U), Underwriters Laboratories (UL 50/UL 414), and the National Electrical Code (NEC).
- (e) All meter sockets shall have an appropriate label or labels certifying compliance of all current carrying parts with UL standards.
- (f) All meter sockets must be able to be tamper-sealed with one seal and shall be in serviceable condition.
- (g) All meter sockets shall be equipped with a grounding lug which shall be bonded to the neutral bar **and connected to a grounding electrode by means of an effectively grounded conductor.**
- (h) All meter sockets, except residential single-phase sockets or commercial sockets of 200 Amps continuous rating or less, shall have a manual, mechanical, gang operated lever bypass switch. A horn bypass is not an acceptable substitute.
- (i) The connectors in 320 Amp meter sockets must accept a conductor up to 600 MCM for a single wire connector or up to 350 MCM per lug for a dual wire connector.
- (j) For meter sockets with five terminals, the fifth terminal must be physically secured to the meter socket block. It may be removable, and, if so, must be securely attached to the socket in the appropriate operating position with a screw or bolt.
- (k) The meter socket shall be large enough to accommodate the appropriate conductor size and must have adequate wire bending clearances per the NEC. The Customer shall properly seal all unused openings on the meter socket assembly.
- (l) Connectors in all meter sockets shall be of adequate size and ampacity to match the service entrance size. Under no circumstances shall multiple wires be acceptable utilizing a single connector.
- (m) In accordance with all applicable codes, a socket shall be properly installed and used in the application for which it is designed:
 1. Sockets intended for overhead (OH) service installations shall be labeled for overhead use, and may be of side wire or center wire entry design.
 2. Meter sockets intended for underground (UG) service installations shall be labeled for underground use, and shall be of left side, side wire design. (Refer to Appendix I, Figures I-2, I-4, I-6, I-8, I-10, and/or I-12)
 3. Dual use sockets, that is, sockets designed for either Overhead or Underground use, are acceptable for either Overhead or Underground, but if used for Underground service, shall be left side, side wire design.
 4. Exception: Where the service entrance equipment must be wired to the left of the meter socket, a right side, side wire design meter socket may be substituted for use with underground service entrances.

8.3.2 Combination Meter Socket Units: Combination self-contained units, i.e. meter socket/breaker panel units or meter socket/generator transfer switch units, shall conform to all of the requirements in 8.3.1 with the following additions or exceptions:

- (a) Units intended for underground service installation shall be constructed with a tamper-proof wire way which isolates the Cleco service lateral conductors from the Customer's load center section of the unit.

ELECTRIC SERVICE STANDARDS

- (b) Combination units intended for underground service are not required to have a side wire design if the unit complies with all NEC wire bending requirements and all other Cleco requirements.
- (c) The section of the unit which contains the meter block must be tamper-sealed with a single seal.
- (d) Bypass and/or switching mechanisms shall be lever operated.

8.3.3 Compliance: Units which do not comply with the Cleco standards as set forth in 8.3.1 and/or 8.3.2. as applicable, shall not be connected to the Cleco system. Service will not be connected to a meter socket where Cleco's service wire runs through that section of the meter to which the Customer has access.

8.4 Inspection and Approvals

The Customer's service installation shall be in accordance with NEC and/or local codes. The Company does not inspect premise wiring, except for protection of the Company's service and equipment. The Company shall be under no obligation whatsoever to inspect the Customer's installation and equipment. Where local wiring ordinances are in effect requiring inspection and approval of the Customer's wiring by local inspection authorities, the inspection shall be completed and certificate of approval secured before the Company renders service. The Company reserves the right to not connect any new service, and the right to disconnect an existing service should the Customer's wiring or equipment be deemed unsafe or in non-compliance with these Service Standards. When an existing meter installation is disconnected, the installation shall be made compliant with current NEC standards prior to reconnection.

8.5 Location of Meters

Meters shall be located in an accessible area that is relatively free from the threat of mechanical injury to the meter and an obstruction free, safe working space shall be provided. The space shall be measured at least from grade or floor for 6 ½ feet in height, horizontally the width of the service entrance equipment plus 3 feet on both sides, and 3 feet plus the width of the service entrance equipment on the front side. Because commercial and industrial installations typically vary in each case, it is recommended that the Customer consult the Company before final plans are completed. Generally, the Company does not allow meters to be placed inside a building or in any sort of enclosed structure. However, in extraordinary circumstances, an exception may be made. Refer to Sections Special High Density Multiple Occupancies With Underground Service: An interior "*Meter Equipment Room*" may be permissible due to the large number of service entrances required and external space limitations. These "*Meter Equipment Rooms*" are subject to the following additional requirements: Refer to Sections 7.20.3 and 8.5.2 for exception requirements.

8.5.1 Meter Mounting Height: To facilitate reading, resetting, and servicing, the preferred mounting height of a single meter should be 5 feet, 6 inches above finished grade to the center of the meter, but shall not be more than 6 feet or less than 5 feet. Where two meters are mounted vertically on a wall as a gang installation at one location, the upper meter shall be mounted 6 feet to center above finished grade. The lower meter shall be mounted so as to allow 3 inches clearance between meter sockets. Where more than two meters are to be installed as a gang installation, they shall be mounted in horizontal rows. Individually metered apartment complexes, mobile home parks, and marinas may have meters installed in manufactured combination meter socket and switch gear assemblies. Each meter socket shall be permanently marked to indicate the apartment number, boat slip, or lot number. Such assemblies shall not have more than six rows of meters. When assemblies are mounted on the exterior walls of a building, the center of the highest meter shall not be more than 6 feet above finished grade and the center of the lowest meter shall not be less than 34 inches above finished grade. The Company shall not connect any Customer which does not comply with these standards.

8.5.2 Meter Mounting Height on Raised Structures: Refer to Fig. II-14 located in Appendix II. In certain locations which are subject to flooding, local code or governmental requirements may stipulate that the service entrance be located, or in the case of existing services, relocated above the anticipated maximum flood elevation. Under these circumstances, the Customer may locate the service entrance and meter above the 6 foot maximum mounting height, subject to the following conditions:

- (a) To facilitate reading, resetting, and servicing, the preferred mounting height of the meter should be 5 feet, 6 inches above the floor to the center of the meter, but shall not be more than 6 feet nor less than 5 feet.
- (b) The floor shall be considered any permanently elevated walkway that forms the normal path of egress to the structure, such as the porch, foyer, or stairway landing. (Stairways, special platforms, or walkways other than those intended for primary egress shall not be allowed.)
- (c) A minimum of 4 feet clear working space between the front side of the meter and any opposing wall or railing shall be provided.

ELECTRIC SERVICE STANDARDS

- (d) Meter installations may be recessed into walls and / or be located behind false panels for aesthetic purposes upon prior approval by the Company and shall meet any applicable building codes, plus the additional requirements listed below:
1. The Company reserves the right to review the service entrance equipment and wiring both prior to being enclosed, and following enclosure to assure access and operability.
 2. The meter shall always be readily accessible. (The Company shall have access to the meter without entering the structure and the wall panel or cover hiding the meter shall be removable with a minimum of effort, i.e. a hinged door or a lift out panel.)
 3. The enclosure shall be permanently identified with a placard indicating "Electric Meter Within" and (where applicable) "Service Disconnect Within". The placard shall not be smaller than 6 inches by 6 inches in contrasting colors of black on red and shall be permanently affixed to the outside of the enclosure cover or door and displayed in a readily viewable location.

8.5.3 Meters on Company Poles: The Company shall not allow the installation of meter sockets and/or metering equipment on any Company pole, except for those used in conjunction with primary voltage metering installations and Joint Use applications.

8.6 Number and Size of Service Conductors

The number and size of service entrance conductors are determined by the class and type of service offered by the Company and the class and type the Customer or his duly authorized designee elects to receive. The service entrance conductors and equipment for single family dwellings shall have a minimum capacity of 150 amperes. (The Company requires a minimum service capacity of 150 amperes for residential dwellings). Service entrance conductors and equipment less than 100 amperes shall be limited to special small load applications such as signs, traffic and signal lights, telephone booths, cable television amplifiers, temporary service, etc. Large commercial and industrial service conductors should not be larger than 750KCM. If multiple runs of service conductor are anticipated, Cleco's engineering representative must be consulted. See Table 8.1 below.

MAXIMUM SERVICE CONDUCTORS ALLOWED PER PHASE		
SERVICE VOLTAGE	MAIN BREAKER FRAME	MAXIMUM ALLOWED 1/0 - 750kcmil
277/480V	6300A	16
277/480V	6000A	16
277/480V	5000A	15
277/480V	4000A	12
277/480V	3000A	9
277/480V	2000A	6
277/480V	1600A	5
277/480V	1200A	4
277/480V	800A	3
277/480V	600A	3
277/480V	400A	3
277/480V	250A	3
277/480V	200A	3
277/480V	125A	3
277/480V	100A	3
120/208V	5000A	16
120/208V	4000A	12
120/208V	2500A	8

ELECTRIC SERVICE STANDARDS

120/208V	1600A	5
120/208V	1200A	4
120/208V	800A	3
120/208V	600A	3
120/208V	400A	3
120/208V	250A	3
120/208V	200A	3
120/208V	150A	3
120/208V	100A	3

Table 8-1: Maximum Service Conductor Allowed

ELECTRIC SERVICE STANDARDS

8.6.1 Meter Sockets as Raceways: Meter sockets, CT cabinets, or Metering enclosures shall not be used as junction boxes, or raceways.

8.6.2 Connectors and Wiring: No more than one wire per lug screw shall be allowed on any connection.

8.7 Grounding of Service Entrance Equipment

The neutral conductor and metallic parts of the service entrance equipment, including meter sockets, all meter enclosures, instrument transformer enclosures, or mounting brackets shall be ~~adequately~~ **effectively** grounded according to the **National Electrical Safety Code (Section 9 and Section 21)**, National Electrical Code (Article 250), and/or any other governing bodies. For reference consult Tables 8-2 and 8-3. The conductor to be grounded shall be as follows:

- (a) The identified Neutral conductor on single-phase, 3-wire services.
- (b) The identified Neutral conductor on three-phase, 4-wire, Wye services.
- (c) The identified Neutral conductor on three-phase, 4-wire, Delta services.

The grounded neutral shall be connected to a suitable, approved grounding electrode system (Figure II-10.) Note: Multiple grounding electrodes spaced no closer than 6 feet apart are required for service entrances where a single grounding electrode has more than 25 Ohms resistance to earth (refer to Figure II-10.) Conduits, metal enclosures, and metallic covering on the wiring system shall be bonded to the above ground connection **using a common ground conductor that shall be effectively grounded**. In no case shall gas or water pipe(s) be used as grounding electrodes for electrical service entrances.

Grounding Electrode Conductor for AC System		
Size of Largest Service-Entrance Conductor or Equivalent for Parallel Conductors		Size of Grounding Electrode Conductor
Copper	Aluminum or Copper-Clad Aluminum	Copper
2 or Smaller	1/0 or Smaller	6
1 or 1/0	2/0 or 3/0	6
2/0 or 3/0	4/0 or 250	4
Over 3/0 thru 350 kCM	Over 250 thru 500 kCM	2
Over 350 kCM thru 600 kCM	Over 500 kCM thru 900 kCM	1/0
Over 600 kCM thru 1100 kCM	Over 900 kCM thru 1750 kCM	2/0
Over 1100 kCM	Over 1750 kCM	3/0

Table 8-2: Grounding Electrode Conductor for AC System

ELECTRIC SERVICE STANDARDS

Grounding Raceway and Equipment		
Rating or Setting of Automatic Over-current Device in Circuit Ahead of Equipment, Conduit, etc., Not Exceeding (Amperes)	Size	
	Copper Wire No.	Aluminum or Copper-Clad Aluminum Wire No.
15	14	12
20	12	10
30	10	8
40	10	8
60	10	8
100	8	6
200	6	4
400	3	1
600	1	2/0
800	1/0	3/0
1,000	2/0	4/0
1,200	3/0	250 kCM
1,600	4/0	350 kCM
2,000	250 kCM	400 kCM
2,500	350 kCM	600 kCM
3,000	400 kCM	600 kCM
4,000	500 kCM	800 kCM
5,000	700 kCM	1200 kCM
6,000	800 kCM	1200 kCM

Table 8-3: Grounding Raceway and Equipment

8.8 Service Entrance from Overhead Service

The service entrance conductors and equipment shall be in accordance with NEC and shall be securely fastened and waterproof. The service entrance shall be installed, owned, and maintained by the Customer. In general the service head must be above the service drop attachment and high enough to provide the required clearances per Section 7.9.1. If the height of the building will not permit the location of attachment to provide minimum clearances for the service cable, a service mast must be provided. The Customer shall provide the required conductors in the service entrance equipment and leave sufficient length of wire, approximately eighteen (18) inches, outside the service entrance head for connection to the Company's service cable. For proper clearances, refer to Appendix II, Figures II-7 and II-8.

8.9 Conduit Riser for Overhead Services

Conduit riser for overhead services shall meet the following requirements:

- (a) The minimum size conduit riser to be installed between the meter socket and service head shall be 1 ½" for the service entrance conductors only.
- (b) Conduit risers sized for use with various sockets and enclosures shall be 2" up to 4" for both single and three-phase heavy duty sockets at 200 to 400 amperes.
- (c) Where PVC conduit is used with a metallic weather head, the metallic weather head shall be effectively grounded.
- (d) Rigid Metal Conduit (RMC) or Intermediate Metal Conduit (IMC) used as a service mast shall be at least 2" I.D., and shall be able to withstand a minimum load of five hundred (500) pounds in any horizontal direction from the point of attachment of the service drop (refer to Appendix II, Figure II-7.)
- (e) Conduit risers shall not be reduced (belled or bushing) in diameter to permit fitting a small conduit hub in meter sockets or enclosures.

ELECTRIC SERVICE STANDARDS

8.10 Conductor in Conduit Riser for Overhead Service

The Customer shall furnish, own, and install conductors (unspliced and without taps) from a point approximately 2 feet beyond the service head in all installations, to the service entrance equipment. When multiple weather heads are used, two additional feet of conductor shall be added for each weather head in order for the service entrance conductors to be connected at a common point to the service drop.

8.10.1 Service Entrance Wiring: An additional 2 feet of service entrance conductor must be furnished per additional service mast. (Refer to Section 8.11 for additional requirements.) Single or parallel service entrance mast(s) or underground risers may be used for large services and multiple metering applications where the service entrance conductors first terminate in a Customer owned service disconnect on the source side of the metering enclosure(s), provided the following requirements are strictly met:

- (a) Specific need exists to minimize the number of disconnects to de-energize the building (more than 6 meters). Note: Factory designed multiple meter centers and commercial metering switchboards are preferred to field assembled systems.
- (b) The service disconnect shall have provisions for the Company to inspect and effectively tamper seal (with padlock) the equipment enclosure, without impairing the functionality of the device.
- (c) Service entrance conductors from the service disconnect to the meter sockets shall not be spliced or tapped, but shall be routed directly from the load side terminals of the service disconnect to the source side terminals of the meter socket. (Taps or connections within a trough or wire way between the service disconnect and the meter socket are NOT Allowed.)
- (d) The load side terminals of the service disconnect shall have no more than one conductor per lug connection.

Note: 277/480V service entrances shall require individual load break disconnects on the source side for each meter installation, regardless of the necessity of an aggregating Main Disconnect on the source side. In all applications where multiple occupancies exist within a single building, the Customer is urged to utilize factory designed meter centers. The factory designed meter centers (including commercial metering switchboards) shall utilize ringless, cold sequence design for any voltage application through 600V.

8.11 Service Entrance Masts

Where the height of the building makes it impractical to attach the service drop at a point to provide for necessary clearances above ground, a service mast or other approved extension shall be furnished and installed by the Customer to permit the point of attachment to be located at a proper height above ground. (Refer to Appendix II, Figures II-3, II-4, II-5, II-6, II-7 and II-8) In general, service masts or other types of extensions shall conform to the following specifications:

- (a) Must be able to withstand a minimum load of 500 pounds in any horizontal direction from the point of attachment of the service drop.
- (b) Shall be constructed of RMC or IMC, the minimum size shall be two inches I.D.
- (c) The unsupported height of the service mast or "extension" shall not be more than:
 1. Thirty inches for 2" conduit.
 2. Thirty-six inches for 2 1/2" conduit.

Note: Other types of extensions designed to conform to (a) above may also be used after being approved by the Company. Cable TV, telephone, satellite, broadcast TV, or radio antennae attachments are NOT allowed on service masts.

8.11.2 When rigid conduit extensions are provided, the Company will furnish and install a suitable bracket to which the service drop will be attached. When the extension is constructed of other material, consult the Company for proper installation.

8.11.3 Metallic conduits or brackets used as a "service mast" or "extension" must be electrically bonded and grounded to the ground wire terminal in the meter socket enclosure.

8.11.4 The Company reserves the right to refuse to attach its service drop to any "service mast" or "extension" considered to be a hazard to public safety.

8.11.5 The Company assumes no responsibility for any failure of Customer owned service mast or extension.

ELECTRIC SERVICE STANDARDS

8.12 Service to Mobile Homes/Mobile Home Parks/Boat Slips/Marinas

Cleco will furnish meters and service drops/laterals. The meter socket and meter loops will be furnished and installed by the Customer. The Customer shall install the service pole or meter pedestal in accordance with the Company's requirements. (Refer to Appendix III)

8.13 Service Entrance from Underground Source

The service entrance equipment shall be installed in accordance with the provisions of the National Electrical Code. The meter enclosure shall be securely fastened to the exterior wall with a preferred installation height at center of 5 feet 6 inches, but shall not be more than 6 feet or less than 5 feet. The premise wiring shall commence at the line side lugs of the meter socket or junction box. The customer will be responsible for supplying and installing the conduit riser to the meter enclosure. This riser shall be of PVC (schedule 80 minimum), or rigid metallic, fastened to the wall at 2' 6" intervals. The customer shall also be responsible for furnishing and installing a ground wire, ground wire conduit, and grounding electrode. For additional details, please refer to Appendix III, Figures III-9, III-10, and III-11. (Note: For metallic conduits the customer must also furnish and install a bonding clamp and jumper to the grounding electrode.) For service greater than 400A, refer to Appendix IV.

8.14 Disconnecting Means for Service Less than 600 Volts

The Customer shall provide each set of service entrance conductors with a means of disconnecting all energized conductors from the source of supply. The disconnecting means may consist of not more than six load break switches or six manually operable circuit breakers in a common enclosure or in a group of separate enclosures. Two pole breakers, three pole breakers, or multiple single pole breakers may be used on multi-wire circuits provided they are equipped with " handle ties" making it practical to disconnect all energized conductors with no more than six operations of the hand. The disconnecting means must be located at a readily accessible point near the entrance of the conductors, either outside the building wall or immediately upon entering the building. The equipment must also bear the UL approved seal for use on service entrances and be suitable for the prevailing conditions, such as exposure to weather. Refer to Article 230 of the National Electrical Code.

8.14.1 For Service Less than 480 Volts: The disconnecting means for individual and multiple 120/240V, single phase, three wire; 120/208V, two-phase, three wire; 120/240V, three-phase, four wire; and 120/208V, three-phase, four wire services shall be located on the load (customer) side of the metering enclosure. (Refer to Section 8.10.1 for multiple metering installations.)

8.14.2 480 Volt Load break Disconnect: For 277/480V, three-phase, four wire services, The Customer shall furnish and install a non-fused load break disconnect switch, sized per NEC requirements, on the source (Company) side of each metering enclosure. The switch shall be the enclosed type with quick-make and quick-break operating mechanism with locking provisions on the handle. Pull-out type disconnect switches are not acceptable. This switch will be locked by Cleco and shall only be operated by Cleco personnel. A separate, properly sized overcurrent protective device shall be installed on the load side of the metering enclosure per NEC requirements and/or local codes. In all applications where multiple occupancies exist within a single premise, the Customer is urged to utilize factory designed meter centers. The factory designed meter centers (including commercial metering switchboards) shall utilize ringless, cold sequence design.

8.14.3 480 Volt Load break Disconnect - Exception: For individual 277/480V services exclusively served from a single transformer or transformer bank, and only with prior approval of the local Cleco engineering group, the transformer high-side disconnects may be the means used to de-energize the metering equipment. The high-side disconnects shall be operated only by Cleco personnel, and shall not be considered to be the Customer's service disconnecting means. The Customer shall still be required to provide a service disconnecting means and overcurrent protection on the load (Customer) side of the metering enclosure, per NEC requirements and/or local codes for these installations.

8.15 Disconnecting Means for Service Over 600 Volts

The Customer (Contractor, Developer, or Owner) shall provide a means of disconnecting all energized conductors of each service entrance from the source of supply. The disconnecting means shall comply with the requirements of the National Electrical Code and/or local codes.

8.15.1 The service disconnecting means shall simultaneously disconnect all ungrounded conductors and shall have a fault closing rating not less than the maximum short-circuit current available at its supply terminals.

ELECTRIC SERVICE STANDARDS

8.15.2 When the Customer's service equipment is located within a vault or consists of metal enclosed switchgear, the following types of over current protection will be allowed:

- (a) A non-automatic oil switch shall be permitted with fuses. The interrupting rating of this switch shall equal or exceed the continuous current rating of the fuse.
- (b) An automatic trip circuit breaker of suitable current carrying and interrupting capacity.
- (c) A switch capable of interrupting the no-load current of the Customer's transformer and equipped with suitable fuses may be used provided the switch is interlocked with the secondary circuit breaker so that the switch cannot be opened when the circuit breaker is closed.

Note: Metal-enclosed switchgear shall consist of a substantial metal structure and a sheet metal enclosure. Where installed over a combustible floor, suitable protection thereto shall be provided.

8.15.3 Automatic Trip Circuit Breaker: Where the Company's service equipment is not in a vault or metal enclosure, an automatic trip circuit breaker of suitable ampacity and interrupting capacity for over current protection is required. The circuit breaker shall be located outside the building as near as practicable to where the service conductors enter the building. The location shall be permitted on a pole, roof, foundation, or other structure. Where over current protective equipment is used as a disconnecting means it shall simultaneously disconnect all ungrounded conductors and have a sufficient rating to interrupt the maximum available fault current at the Customer's point of service.

8.16 Customer's Utilization Equipment

The Company offers the following suggestions as an aid in maintaining reasonably uniform voltage and continuous service. The type, size, and mode of operation of equipment frequently affect the voltage and the quality of service received. Three wire single phase and all multi-phase circuits should be arranged to maintain load balance on the individual circuits and the main service within ten percent. Larger heating appliances should be connected to 120/240 Volt circuits and arranged to operate 240 Volts on high heat so far as practicable. Operation of single phase motors larger than 1/2 hp at 240 Volts is recommended. Many of these details can be worked out best when the wiring is in the planning stage. The Company recommends that the Customer's wiring be designed so that the voltage drop between the disconnecting means or service entrance switch and the farthest outlet is limited to not more than two percent at full load.

8.17 Motors

Voltage Rating - Single phase motors manufactured under National Electric Manufacturer's Association (NEMA) Standards bear 115 or 230 Volt nameplates and, if three-phase, bear 208, 220 or 230, 440 or 460, and 2300 Volt nameplates. These are nominal voltage ratings and do not imply that the motors be operated only at the listed "nameplate" Voltage. Motors will be supplied with nominal voltages as listed in Table 8-4.

Motor Nominal Supply Voltage		
	Nominal Supply Voltage	Motor Voltage Rating
Single-Phase	120	115
	240	230
Three-Phase	208	208
	240*	220 or 230
	480	440 or 460
	2400	2300

Table 8-4: Motor Nominal Supply Voltage

* **Note:** This voltage not available for motors over 20 Hp.

All motors served from the Company's lines shall bear a manufacturer's nameplate indicating the voltage, current rating, speed, and horsepower rating for continuous and intermittent use as the case may be. This nameplate shall also carry the NEMA "code letter" designation of the motor. When a motor is rewound to produce a change in its original design, a new nameplate shall be attached indicating the new characteristics and the name of the firm or person making the change.

ELECTRIC SERVICE STANDARDS

8.18 Motor Starting Currents

Most motors, when started at rated voltage, draw currents far in excess of full load running current. Excessive starting currents may cause an abnormal drop in the supply voltage resulting in light flicker or possible undesirable operation of protective equipment. Thus, it is essential that the Customer's equipment have good starting characteristics to avoid annoying flicker effects to the Customer as well as other nearby Customers.

8.18.1 Single-Phase Motors - Horsepower Rated: Many of the smaller single-phase motors rated in horsepower may be started "across the line", that is, at full rated voltage by merely closing a switch. Larger motors that have higher starting currents (locked rotor current) than those specified in Table 8-5, may be permitted under the following conditions only:

- (a) When such motors are provided with proper current limiting starting equipment, or
- (b) When the locked rotor current of each motor in an installation is less than that of the largest motor permitted in the installation, or
- (c) When the total locked rotor currents of two or more smaller motors which may be started simultaneously are less than the allowable locked rotor current of the largest motor in said installation.

Allowable Starting Currents for Single-Phase Motors, Motors Rated in Horsepower		
Equipment Rated	NEMA Letter Code*	Locked Rotor Current
115 Volts 230 Volts		50 Amps
1/3 Hp.	A through V	60 Amps
1/2 Hp.	A through V	60 Amps
3/4 Hp.	A through T	60 Amps
1 Hp.	A through P	60 Amps
1.5 Hp.	A through L	60 Amps
2 Hp.	A through H	60 Amps
3 Hp.	A through G	80 Amps
5 Hp.	A through F	120 Amps
6.5 Hp	A through F	150 Amps

Table 8-5: Allowable Starting Currents for Single-Phase Motors

A "code letter" indicates the locked rotor kVA per horsepower and hence, the locked rotor current. These letters begin with "A" and progress through "V" with the value of locked rotor current increasing in that order.

8.18.2 Single-Phase Air Conditioners: Single-Phase air conditioning units should have starting currents of 30 Amps or less per ton. (See Table 8-6 for starting current limits based on unit's rated output) When starting currents exceed this limit, excessive voltage flicker (momentary voltage dips) may occur that is objectionable to the Customer. Customers are urged to verify, before purchase, that the units obtained have starting currents of 30 Amps or less per ton. Air conditioning units which exceed this limit should have "hard start kits" installed. To minimize flicker the compressor and blower should be staged so as not to start at the same time. Should the Customer's choice of equipment cause excessive flicker for himself and/or others, the Customer may be billed for any corrective measures required by the Company to bring the flicker limit within acceptable tolerance.

Allowable Starting Currents for Single-Phase Air Conditioners Based on Unit's Rated Output		
Rated Output (Tons)	Rated Output (BTUH)	Starting Current (Amps)
1	12,000	30
2	24,000	60
2.5	30,000	75
3	36,000	90
3.5	42,000	105
4	48,000	120
5	60,000	150

Table 8-6: Allowable Starting Currents for Single-Phase Air Conditioners

ELECTRIC SERVICE STANDARDS

8.18.3 Polyphase Motors - Horsepower Rated: Because conditions vary widely at different points on the Cleco system, no specific rule can be written as to what size polyphase motors may be connected, utilizing "across the line" starting or motor starter equipment. It is necessary that the Customer consult the Company in each case when the installation of a motor of 20 horsepower or larger and/or 2400 volts rating is anticipated. Motors of 15 horsepower and less shall have starting currents which do not exceed the values given in Table 8-7. Cleco's Distribution System Planning Engineers will perform a starting analysis and provide appropriate recommendations based on system parameters at each location.

Allowable Starting Currents For Three-Phase Motors Rated in Horsepower			
Rated Horsepower	208 V	220 V	440 V
1	29	27	13.5
1.5	40	37	18.5
2	50	47	23.5
3	62.5	60	30
5	96	90	45
7.5	127	120	60
10	159	150	75
15	233	220	110

Table 8-7: Allowable Starting Currents for Three-Phase Motors

8.18.4 Polyphase Motors - BTUH Rated: For larger homes requiring heating and cooling capacity in excess of a nominal 50,000 BTUH, the Customer should consult the Company to determine the type of service that will be supplied. The Customer should not overlook the possibility of using two or more independent units which can provide better zone control. Where it has been determined that three-phase service will be rendered, motor starting currents shall not exceed the values given in Table 8-8. For motors exceeding these values and for units greater than 180,000 BTUH, it will be necessary to provide facilities to limit the starting current to values specified by the Company for the location involved. See paragraph 8.16.3 above.

Air Conditioning and Heat Pump Equipment Rated in BTU per Hour			
Rated BTUH	208 V	220 V	440 V
20,000 or less	42.5	40	20
24,000	50	47	23.5
36,000	63.5	60	30
60,000	96	90	45
90,000	127	120	60
120,000	159	150	75
180,000	233	220	110

Table 8-8: Air Conditioning and Heat Pump Equipment Ratings

8.19 Motor Protection

8.19.1 No Voltage Release: All motors that cannot be safely subjected to full voltage at starting, or that will not meet the starting current requirements given in Table 8-5, should be provided with a device to insure that motors will be disconnected from the line upon failure of the voltage, unless equipped for automatic starting in case of such failure. In case of the star-delta starting method, the starting switch shall be so arranged that it cannot be thrown into the running position. Motors started by this method shall be equipped with a no-voltage release device.

ELECTRIC SERVICE STANDARDS

- 8.19.2 Time Delay Relays:** Where continuous operation of a motor is essential, the no-voltage release should have a time delay relay which will prevent the opening of the circuit in the event of momentary voltage fluctuation.
- 8.19.3 Phase Reversal Protection:** Reverse phase relays are required on three-phase elevator services (National Electrical Code) and it is strongly recommended that they be installed by the Customer where accidental reversal of motor rotation would cause serious inconvenience, damage, or delay.
- 8.19.4 Over-current Protection:** The Customer shall provide over-current protection specified by the National Electrical Code. Refer to Article 430 of the National Electrical Code.
- 8.19.5 Loss of Phase:** It is strongly recommended that the Customer install properly sized overload protective devices as well as branch circuit fuses on each phase serving a three-phase motor. Proper coordination of these devices should ensure adequate motor protection due to the loss of voltage on one supply phase. The Company assumes no liability for damages resulting from loss of phase in a three-phase service.

8.20 Capacitors and Other Reactive Equipment

The power factor should be held as close to unity as is possible. A low power factor results in the reduction of conductor and equipment capacities, thus reducing the overall efficiency of the electrical system. Where larger capacity motors are to be installed, consideration should be given to the use of synchronous type motors.

8.21 On Site Generation

- 8.21.1 Stand-By Generation:** The Customer may install portable or fixed stand-by generation to supply part, or all, of the electrical load in the event of an interruption in the supply of the Company's service. The Customer shall furnish the Company complete nameplate data on the generator to be installed and consult with the Company on the method of connection to assure the installation of proper and safe equipment.

(a) **Fixed Stand-By Generation:** Solar, Wind, Hydro, Geothermal, Biomass or Engine driven stand-by generation equipment shall always contain a readily accessible, manually operated, lockable disconnect mounted between the generation equipment and the premise wiring. Automatically transferring generating equipment installed for emergency stand-by service shall be connected to the premise electrical wiring by means of a double-throw switch or by interlocked circuit breakers that prohibit the Customer's generation equipment from simultaneously connecting to both the Company's electric supply facilities and the Customer's premise wiring.

(b) **Portable Stand-By Generation:** For installations where a portable generator is to be connected to the premise wiring by a Customer, the Company shall be notified. Portable generators shall only be connected to the premise wiring when the Main Service Disconnect is in the Open or Off position and the generator is adequately bonded to the premise wiring system grounding electrode. Operation in this manner should ensure the safety of both the Customer and Company personnel.

- 8.21.2 Interconnected Generation:** Solar, Wind, Hydro, Geothermal, Biomass, or Engine driven interconnected generation requires an executed "Standard Interconnection Agreement" between the Company and the Customer before the generation equipment is installed. The installation requires equipment certification of IEEE 1547 compliance as well as certification by the electrical authority having jurisdiction and by the Company. Call Cleco at (800) 622-6537 for more information. Generally, the installation is similar to the fixed stand-by generation described above in 8.21.1(a) above, except that it remains simultaneously connected to both the Company's supply wiring and Customer's premise wiring.

Note: Interconnected generation is required to automatically cease operation whenever the utility supply is interrupted and is not intended to provide stand-by power to the premise.

8.22 Surge Protection

Customer owned surge suppressors shall only be installed behind protective fuses or circuit breakers on the load side of the Main Disconnect. For services above 600 volts, surge arrester installations should be made in accordance with recommendations of the Company.

8.23 Public Sign Clearance

Public signs will not be permitted to overhang electric power conductors. Signs must have a minimum horizontal and vertical clearance of 10 feet from conductors operating at voltages between 750 V to 22 kV phase to ground. Care should be taken to ensure that signs or other structures are not erected within a power line right of way. Such construction is considered an encroachment and may be cause for legal action to ensure compliance with

ELECTRIC SERVICE STANDARDS

the terms of the easement or servitude. Clearances of signs from conductors operating at all voltages in excess of 22 kV shall conform to the clearance requirements for buildings as set forth in the National Electrical Safety Code (NESC) and ANSI C2.

8.24 Misuse or Damage to Company's Facilities

The Company's pole, conductors, and other facilities are the property of the Company and the connection to the Customer's premises does not entitle the Customer to any use of such facilities except for the delivery of electric service to the Customer.

8.25 Foreign Attachments to Company Poles

Attachments to the Company poles such as conduits, banners, fire alarms, signs, traffic lights, power and/or telephone wires, and other attachments may be made only with approval of the Company. An attachment agreement with the Company will set forth any criteria. All attachments are to be made with permission and to the satisfaction of the Company. All such attachments must be made in accordance with the specifications of public authorities and NESC where required. Under no conditions shall television or radio antennas be allowed on Company poles.

8.26 Services Larger Than 400 Amperes

Services larger than 400 amperes require special individual attention. Refer to Appendix IV for detailed requirements.

This Page Left Blank Intentionally

APPENDIX I
METER CONNECTIONS

This Page Left Blank Intentionally

ELECTRIC SERVICE STANDARDS

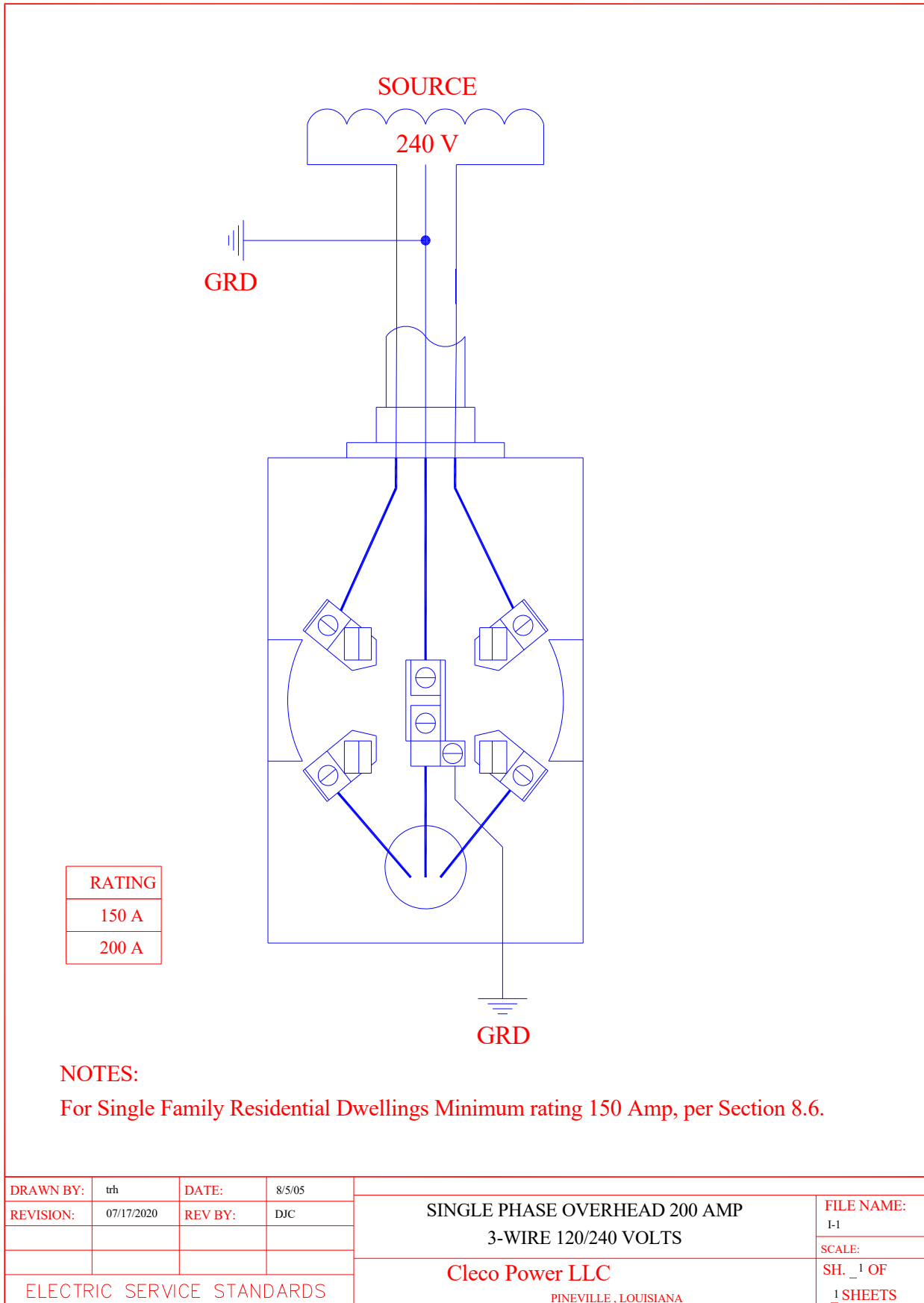

Fig. I-1 Single-Phase OH 200A 3-WIRE 120/240 Volts

ELECTRIC SERVICE STANDARDS

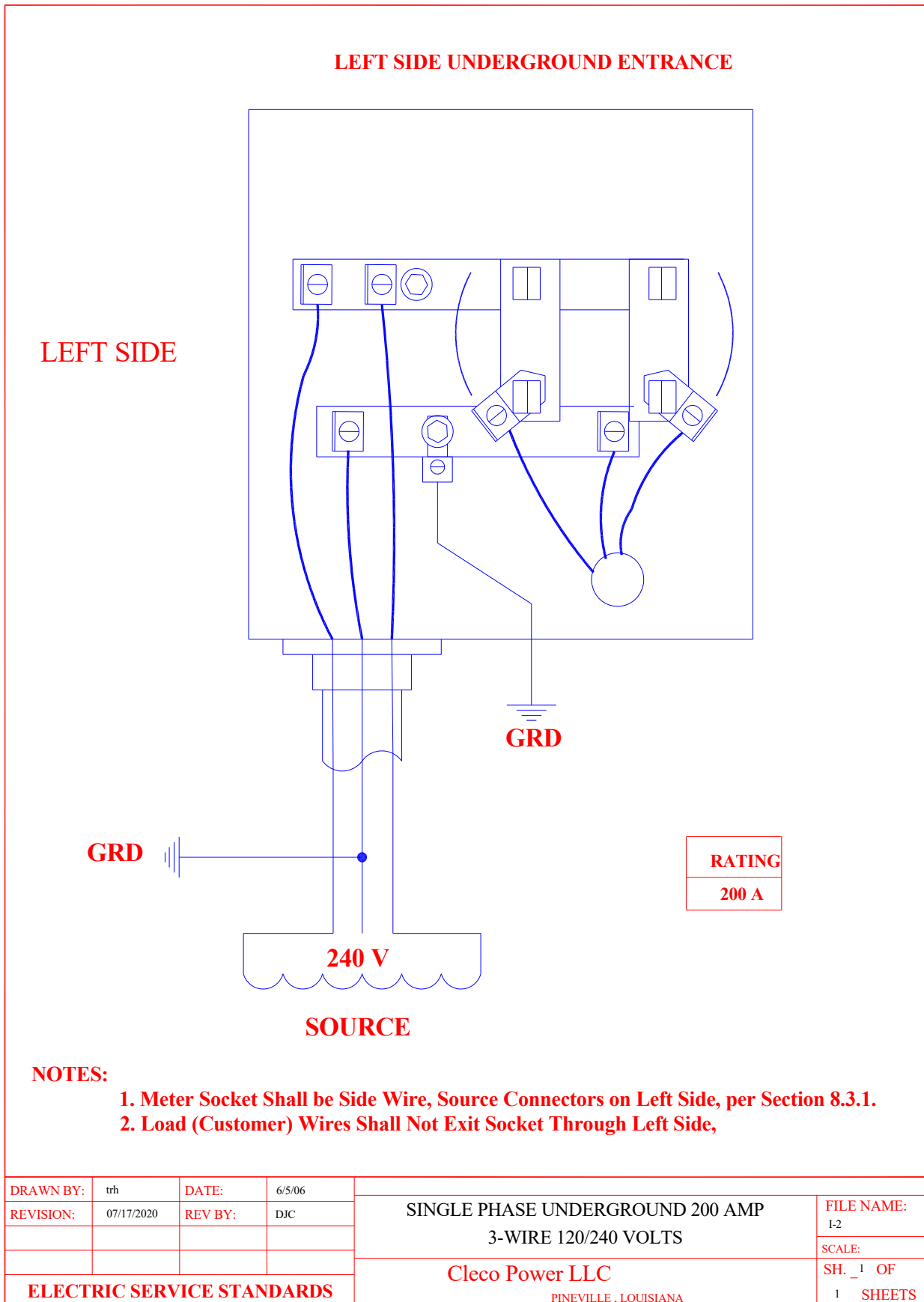

Fig. I-2 Single-Phase UG 200A 3-WIRE 120/240 Volts

ELECTRIC SERVICE STANDARDS

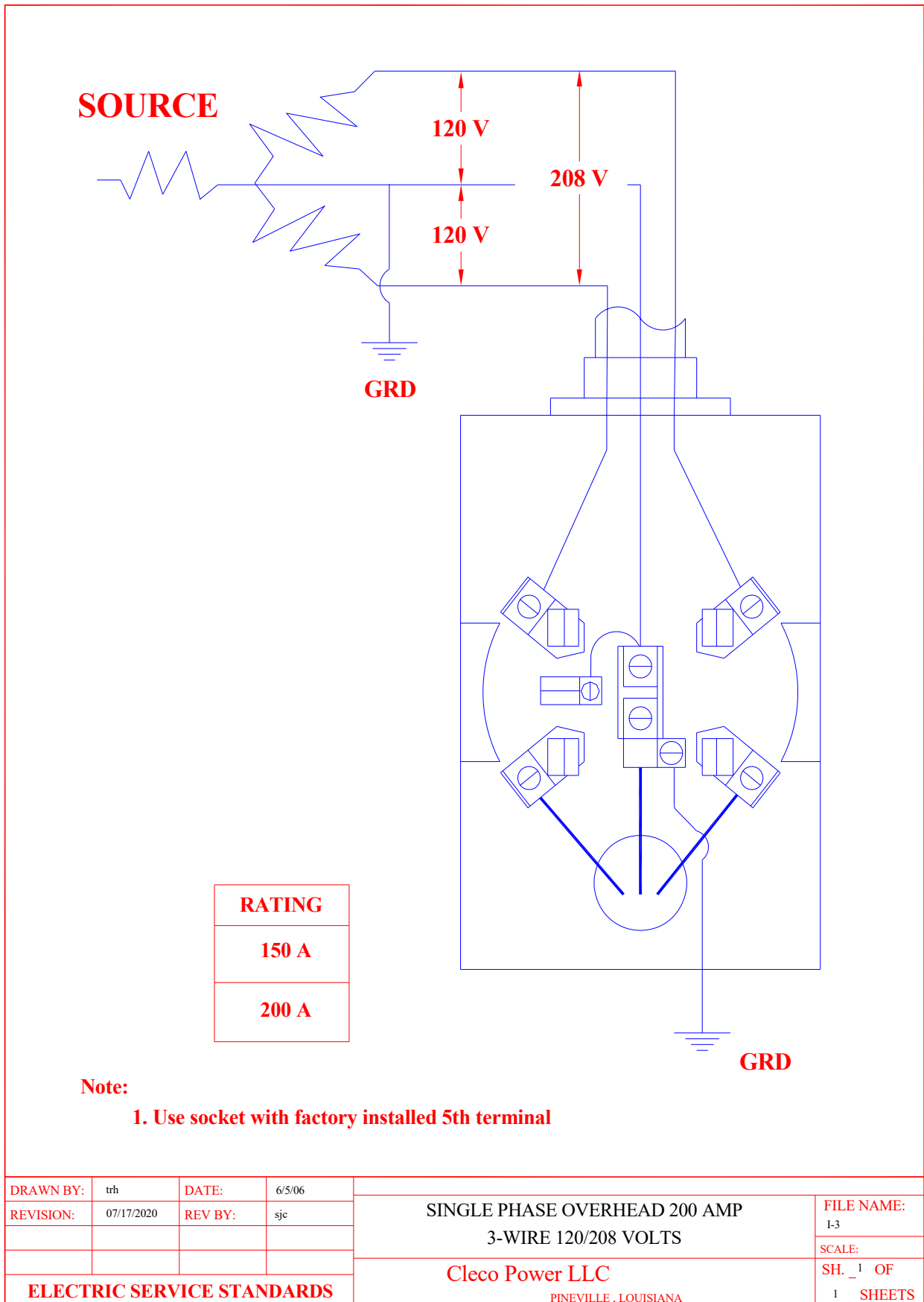
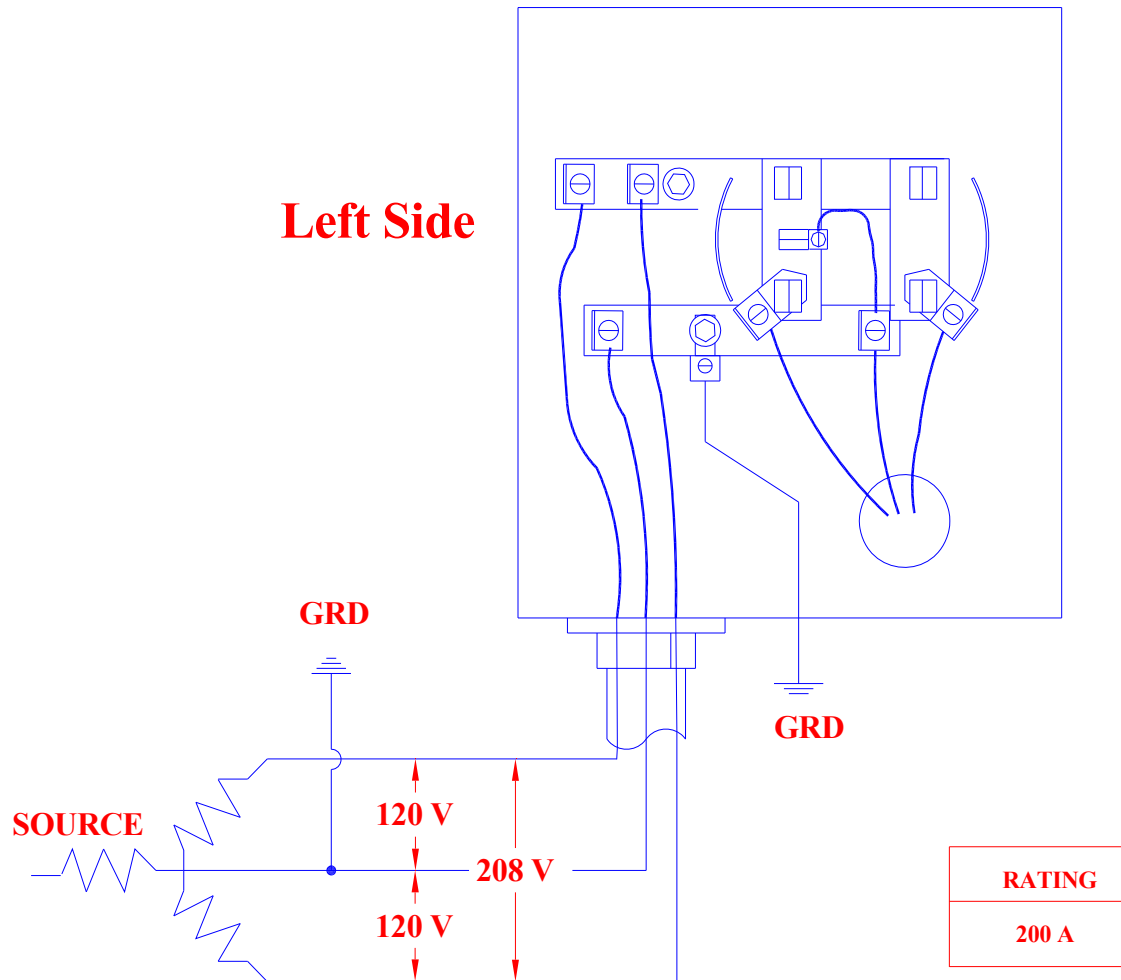

Fig. I-3 Single-Phase OH 200A 3-Wire 120/208 Volts

LEFT SIDE UNDERGROUND ENTRANCE



NOTES:

- 1. Use Socket With Factory Installed 5th Terminal.**
- 2. Socket Shall be Side Wire, Source Connectors on Left Side, per Section 8.3.1.**
- 3. Load (Customer) Wires Shall Not Exit Socket Through Left Side.**

DRAWN BY:	trh	DATE:	6/5/06	SINGLE PHASE UNDERGROUND 200 AMP 3-WIRE 120/208 VOLTS	FILE NAME:
REVISION:	07/17/2020	REV BY:	DJC		I-4
ELECTRIC SERVICE STANDARDS				Cleco Power LLC	SCALE:
				PINEVILLE, LOUISIANA	SH. <u>1</u> OF <u>1</u> SHEETS

Fig. I-4 Single-Phase UG 200A 3-Wire 120/208 Volts

ELECTRIC SERVICE STANDARDS

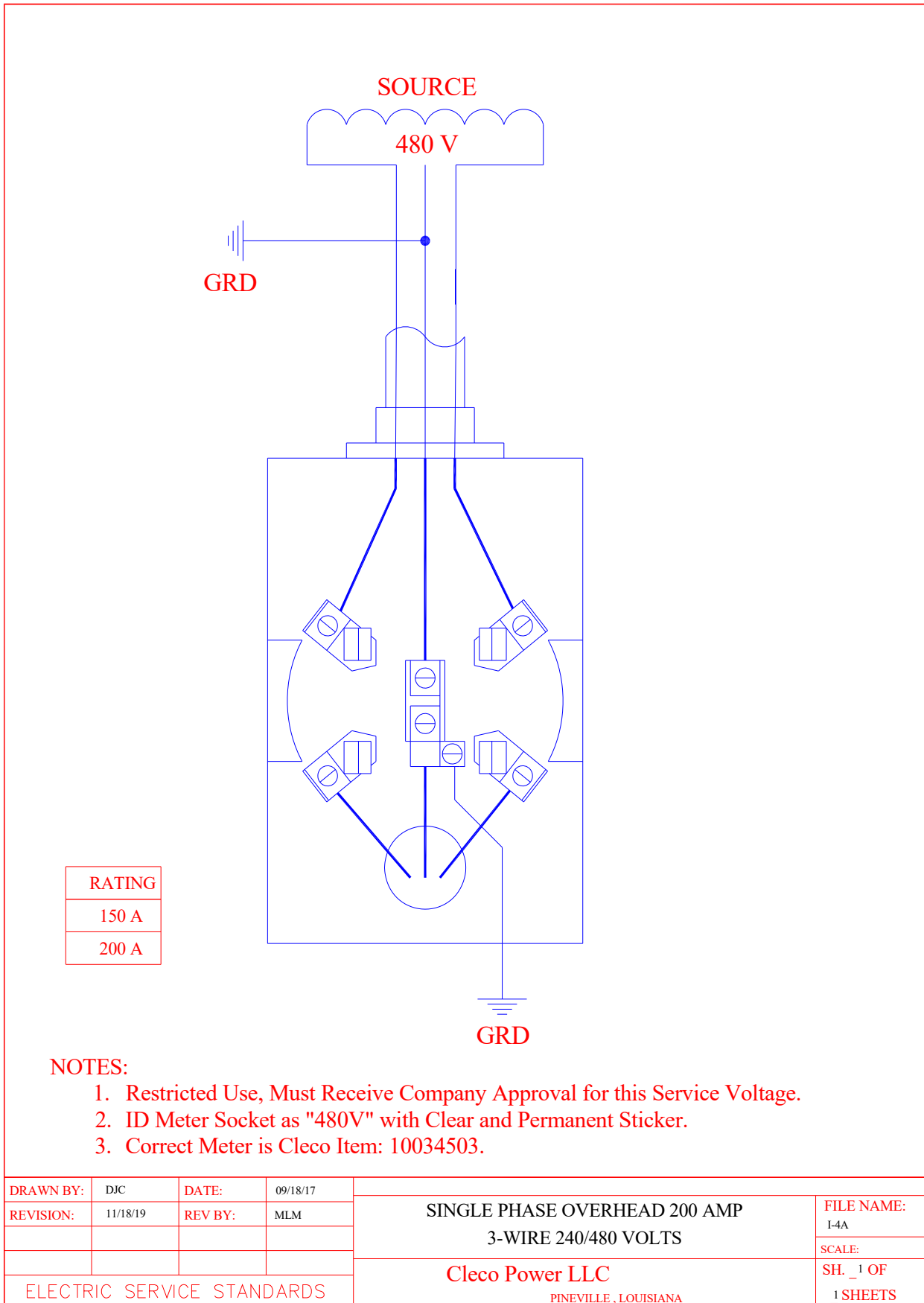

Fig. I-4A Single-Phase OH 200A 3-Wire 240/480 Volts

ELECTRIC SERVICE STANDARDS

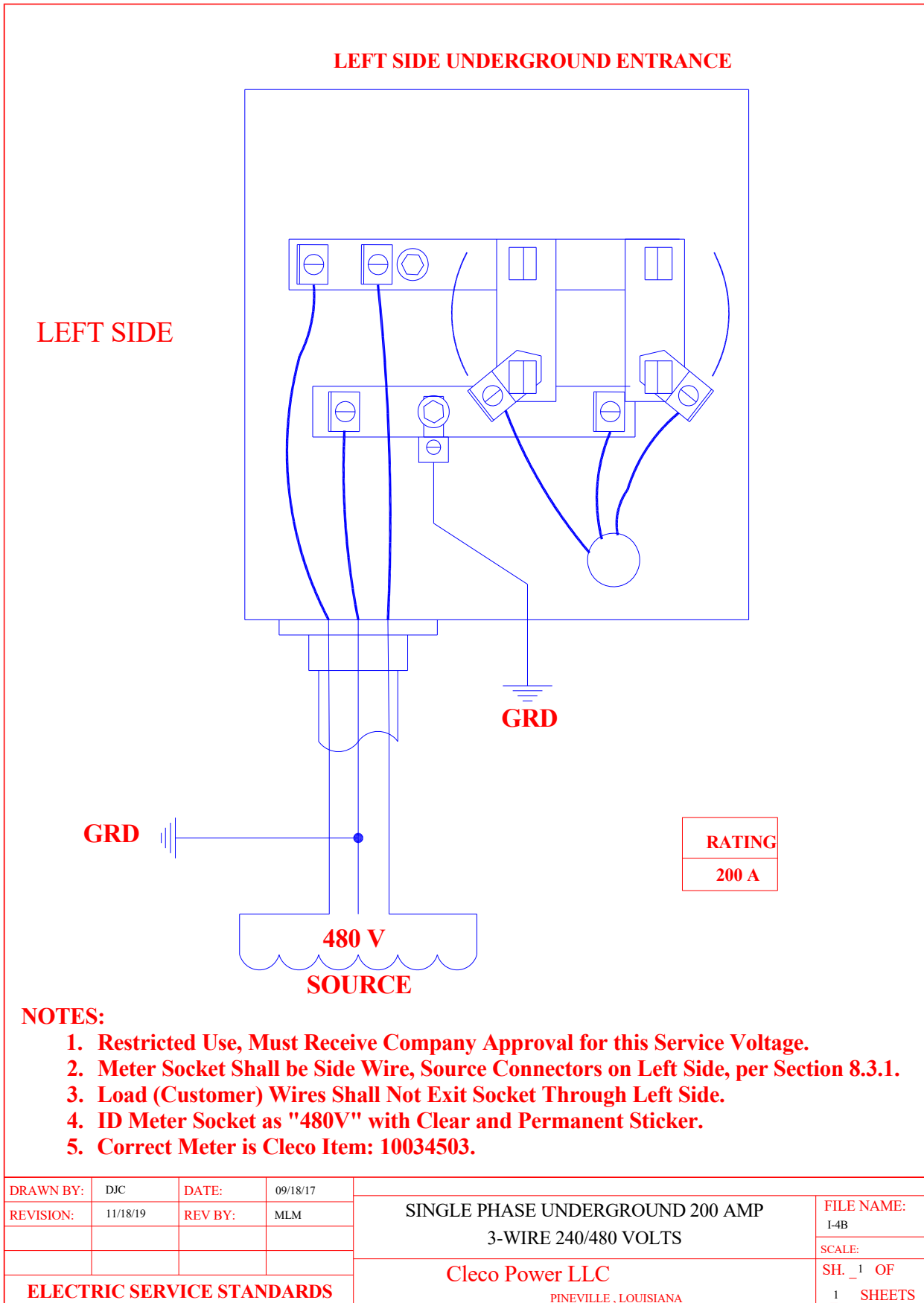

Fig. I-4B Single-Phase UG 200A 3-Wire 240/480 Volts

ELECTRIC SERVICE STANDARDS

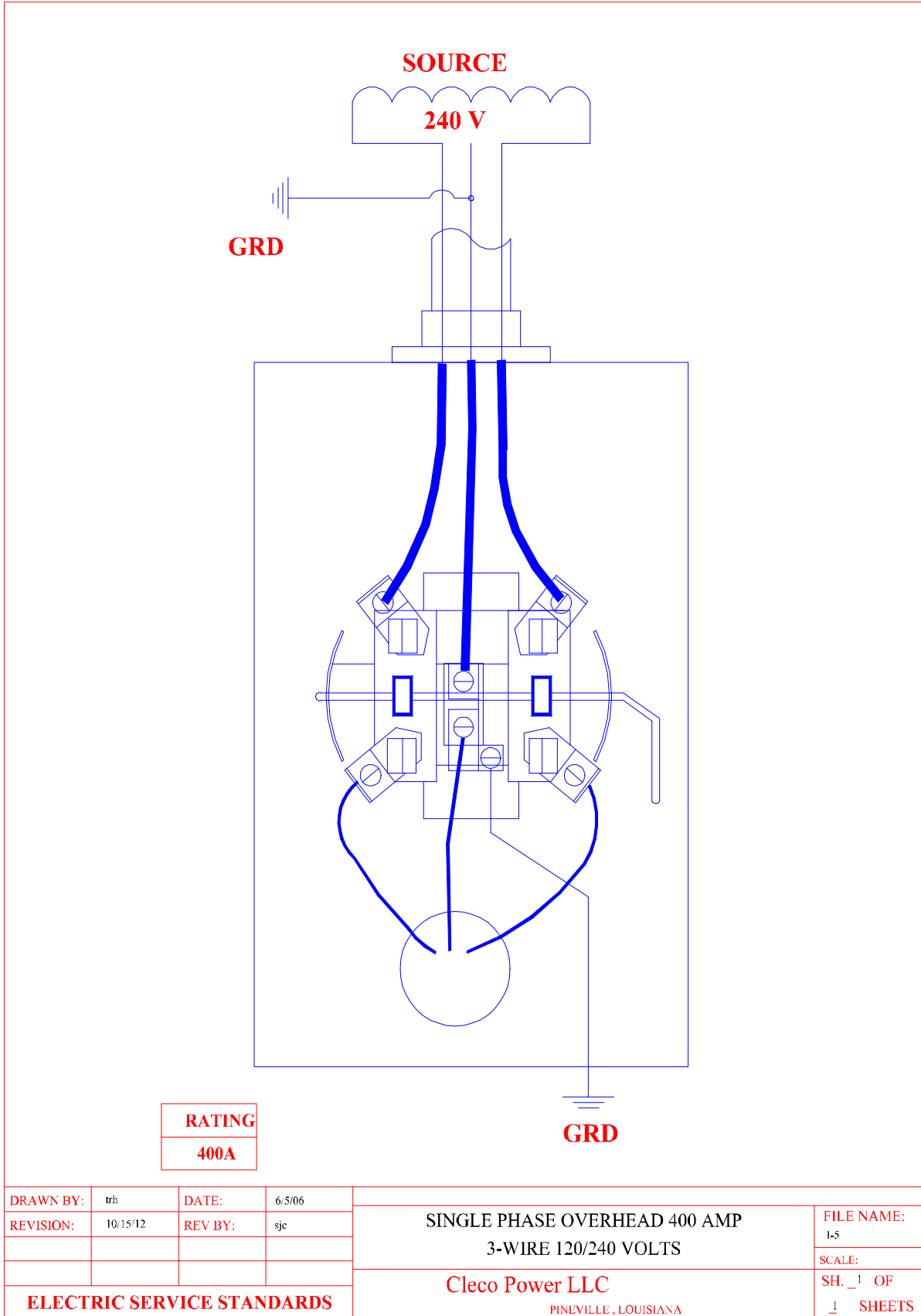

Fig. I-5 Single-Phase OH 400A 3-Wire 120/240 Volts

ELECTRIC SERVICE STANDARDS

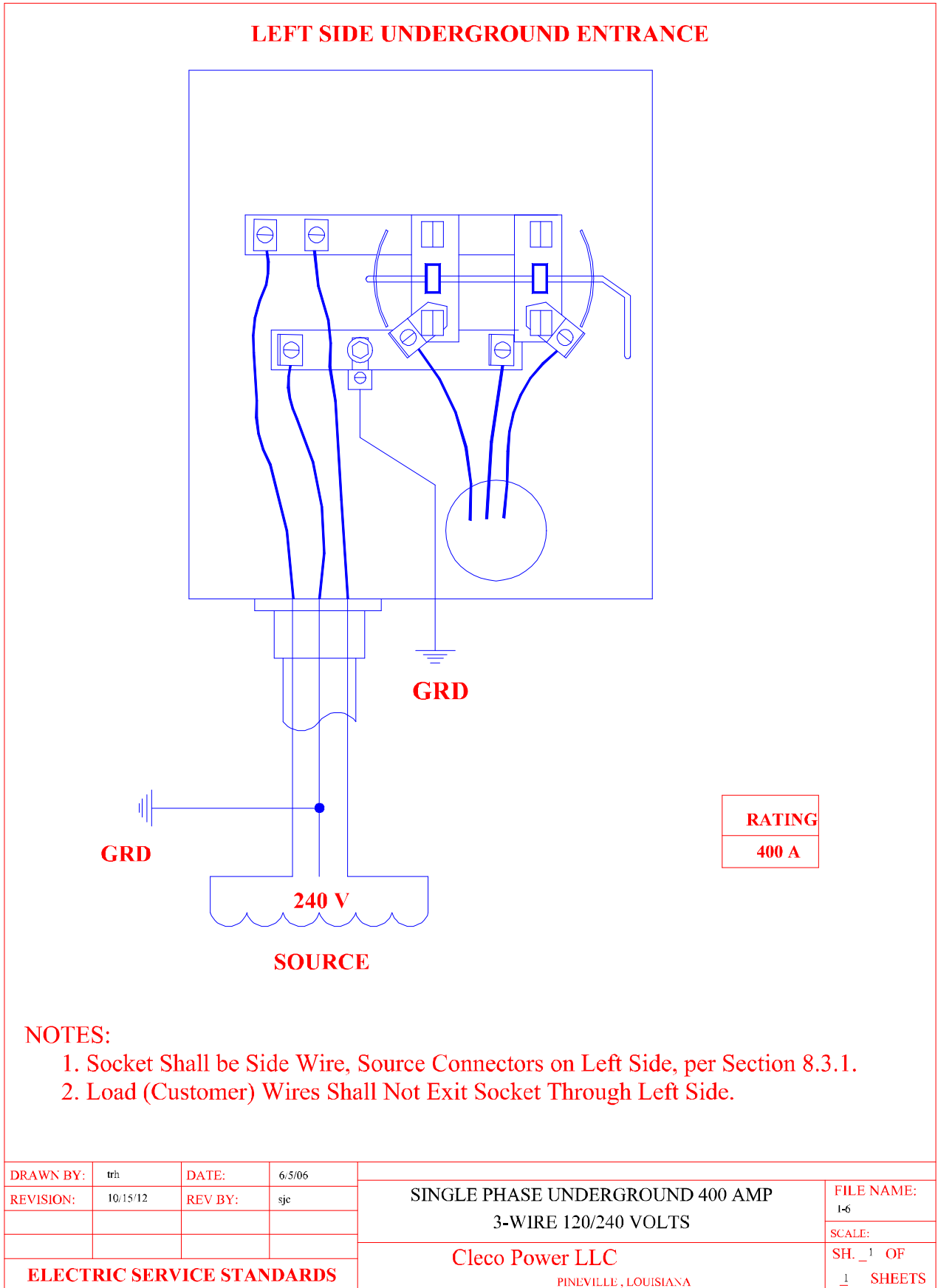
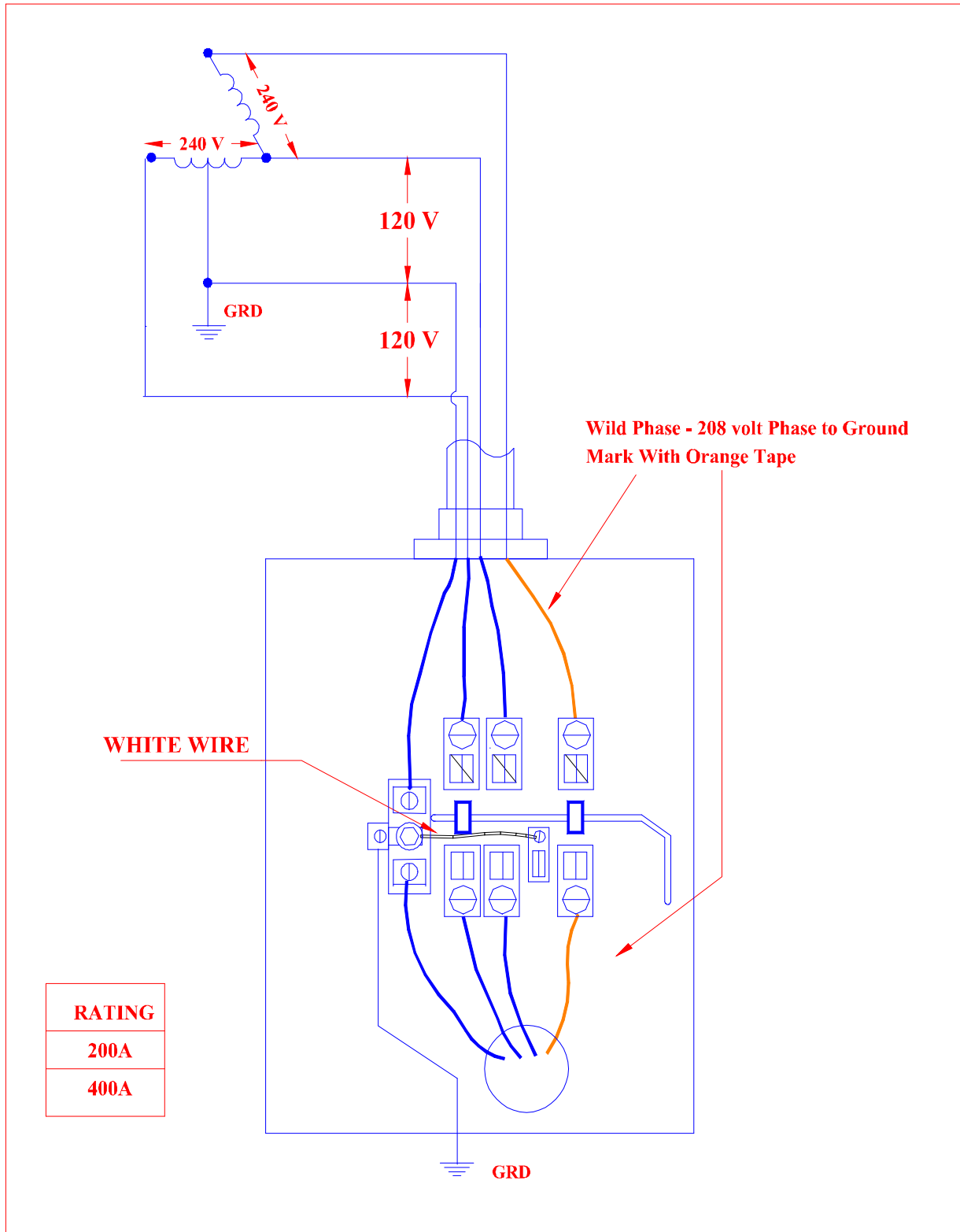

Fig. I-6 Single-Phase UG 400A 3-Wire 120/240 Volts

ELECTRIC SERVICE STANDARDS



DRAWN BY:	trh	DATE:	6/5/06	THREE PHASE OVERHEAD 400 AMP 4-WIRE 120/240 VOLTS	FILE NAME:	I-7
REVISION:	6/5/06	REV BY:	trh		SCALE:	
ELECTRIC SERVICE STANDARDS				Cleco Power LLC <small>PINEVILLE, LOUISIANA</small>	SH. <u>1</u> OF	<u>1</u> SHEETS

Fig. I-7 Three-Phase 120/240 Volts

LEFT SIDE UNDERGROUND ENTRANCE

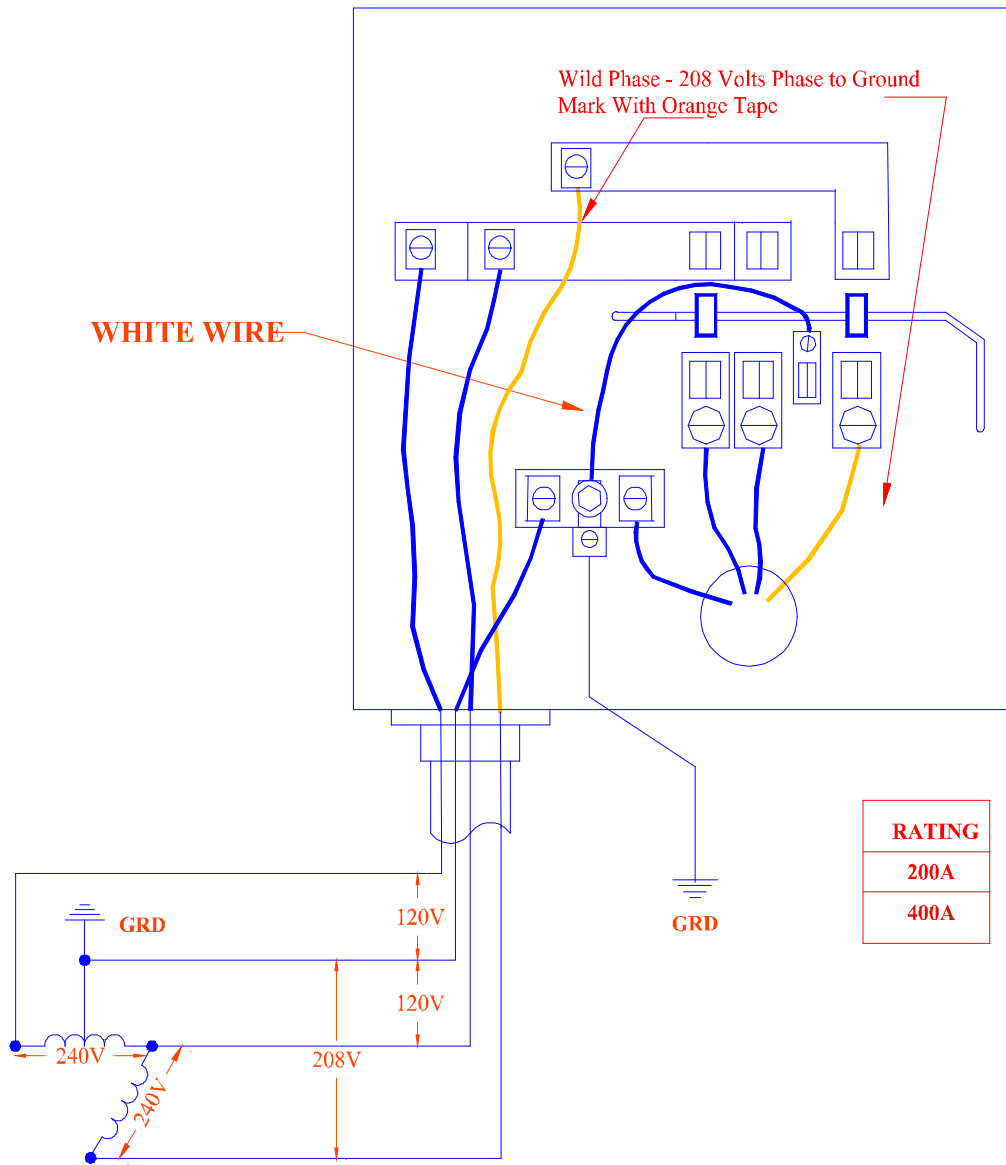

NOTES:

- 1. Socket Shall be Side Wire, Source Connectors on Left Side, per Section 8.3.1.**
- 2. Load (Customer) Wires Shall Not Exit Socket Through Left Side.**

DRAWN BY:	trh	DATE:	6/5/06	THREE PHASE UNDERGROUND 400 AMP 4-WIRE 120/240 VOLTS	FILE NAME:	I-8
REVISION:	10/15/12	REV BY:	sjc		SCALE:	
ELECTRIC SERVICE STANDARDS				Cleco Power LLC	SH. <u>1</u> OF	
				PINEVILLE, LOUISIANA	<u>1</u> SHEETS	

Fig. I-8 Three-Phase UG 400A 4-Wire 120/240 Volts

ELECTRIC SERVICE STANDARDS

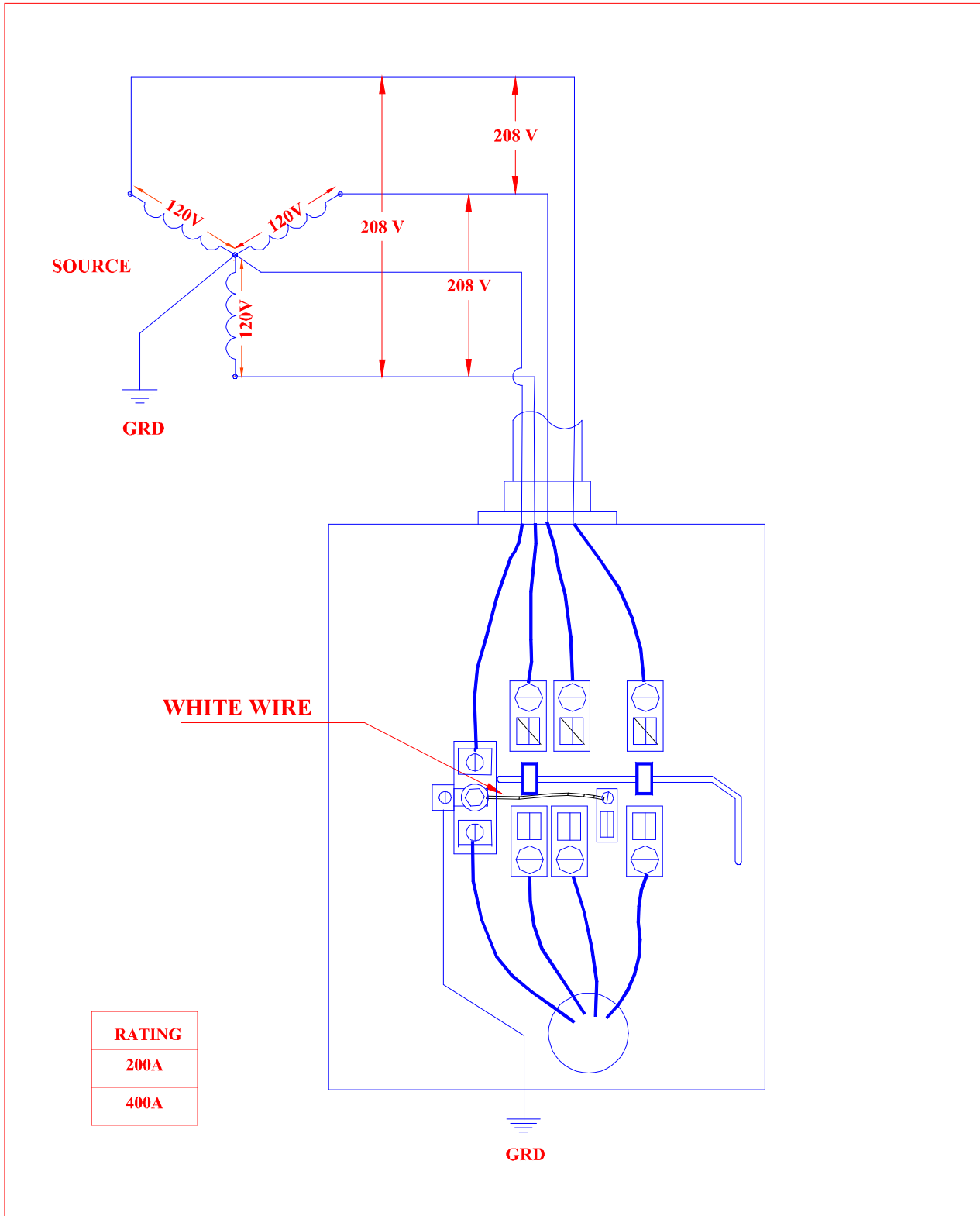

RATING
200A
400A

DRAWN BY:	trh	DATE:	6/5/06	THREE PHASE OVERHEAD 400 AMP 4-WIRE 120/208 VOLTS WYE	FILE NAME:	1-9
REVISION:	6/5/06	REV BY:	trh		SCALE:	
ELECTRIC SERVICE STANDARDS				Cleco Power LLC	SH. <u>1</u> OF <u>1</u> SHEETS	
				<small>PINEVILLE, LOUISIANA</small>		

Fig. I-9 Three-Phase OH 400A 4-Wire 120/208 Volts

LEFT SIDE UNDERGROUND ENTRANCE

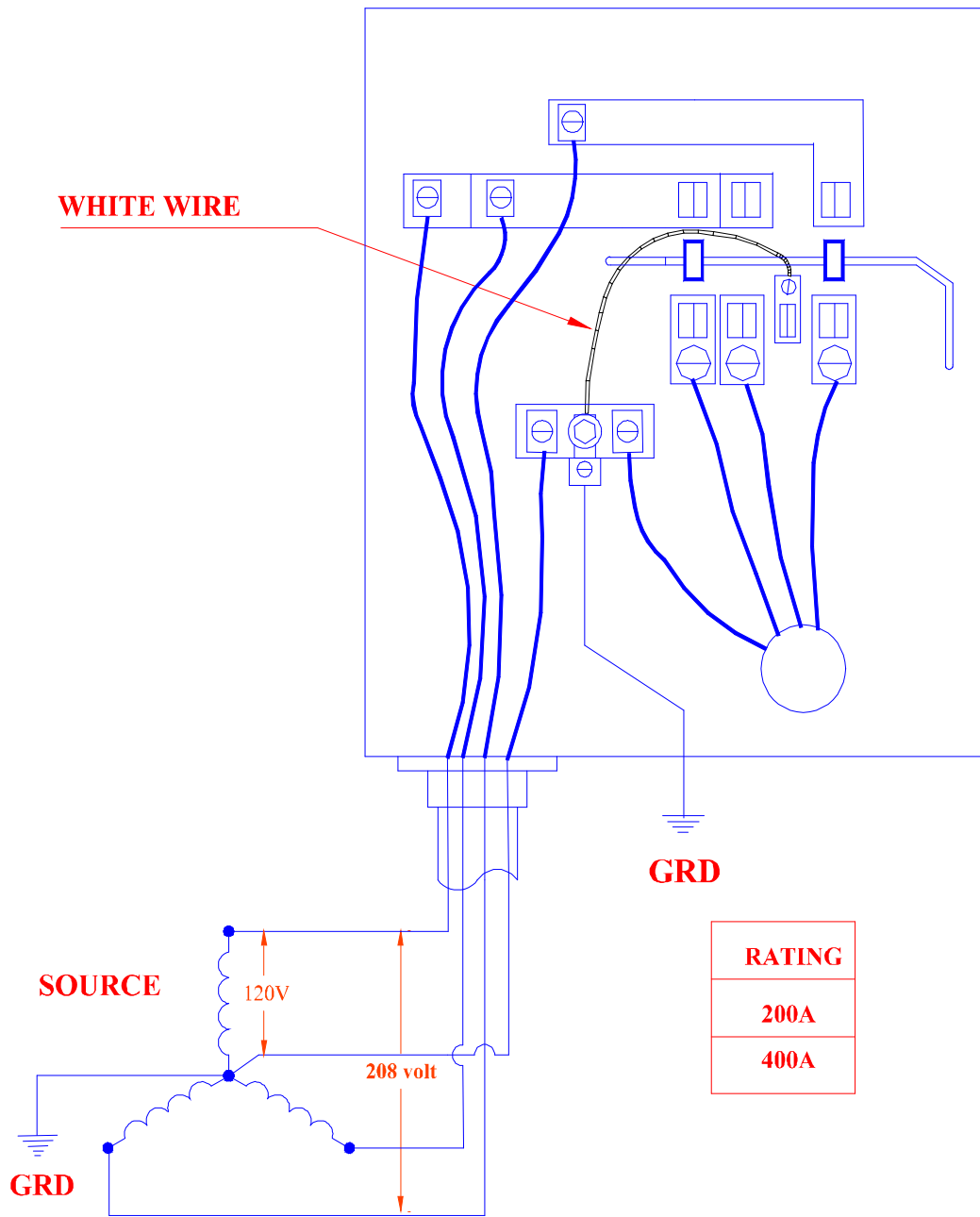

NOTES:

- 1. Socket Shall be Side Wire, Source Connectors on Left Side, per Section 8.3.1.**
- 2. Load (Customer) Wires Shall Not Exit Socket Through Left Side.**

DRAWN BY:	trh	DATE:	6/5/06	THREE PHASE UNDERGROUND 400 AMP 4-WIRE 120/208 VOLTS WYE	FILE NAME:	I-10
REVISION:	6/5/06	REV BY:	trh		SCALE:	
ELECTRIC SERVICE STANDARDS				Cleco Power LLC <small>PINEVILLE, LOUISIANA</small>	SH. <u>1</u> OF	
					<u>1</u> SHEETS	

Fig. I-10 Three-Phase UG 400A 4-Wire 120/208 Volts Wye

ELECTRIC SERVICE STANDARDS

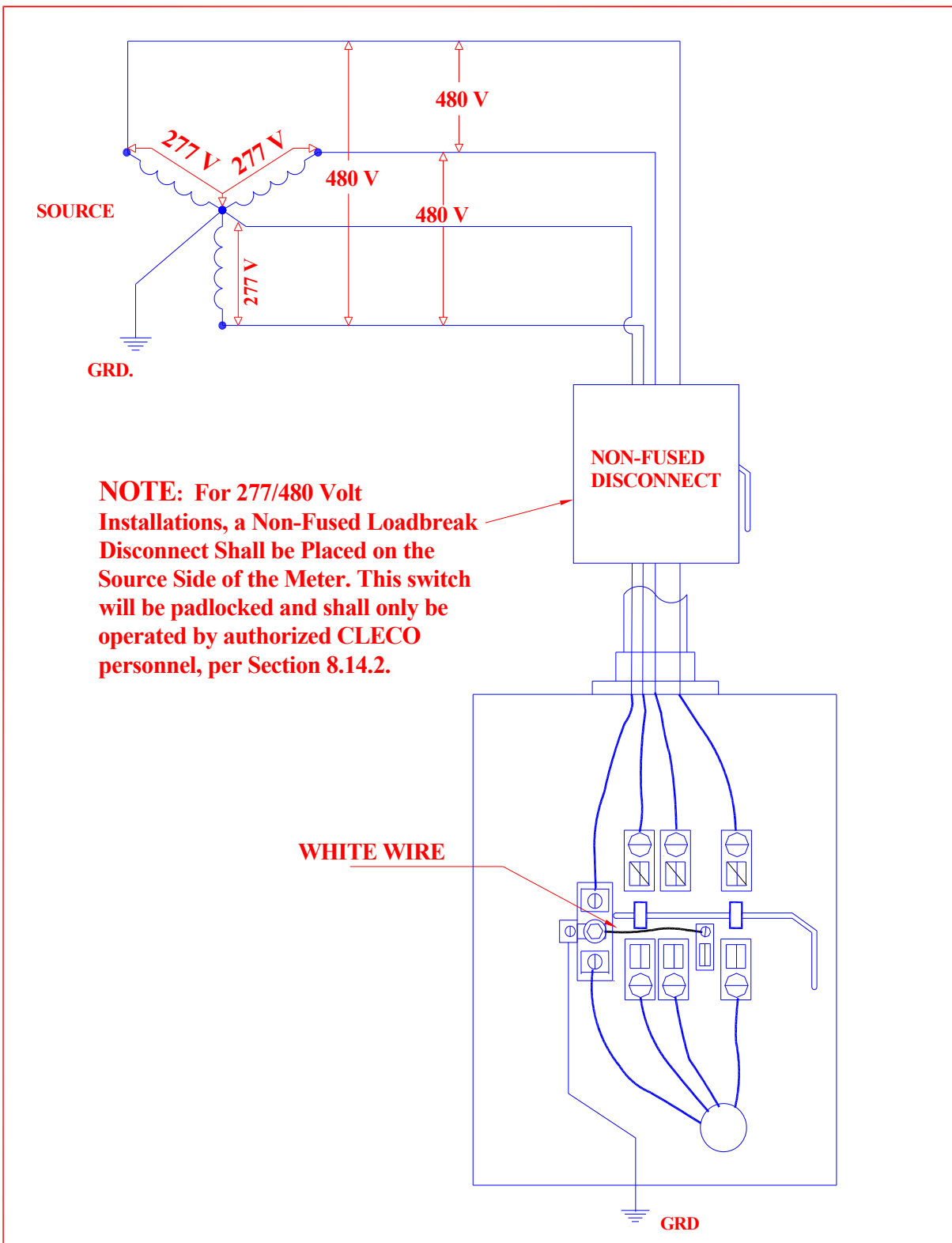

DRAWN BY:	trh	DATE:	6/5/06	THREE PHASE OVERHEAD 400 AMP 4-WIRE 277/480 VOLTS WYE	FILE NAME:	I-11
REVISION:	1/18/2024	REV BY:	MLM		SCALE:	
ELECTRIC SERVICE STANDARDS				Cleco Power LLC	SH. <u>1</u> OF	1 SHEETS
				PINEVILLE, LOUISIANA		

Fig. I-11 Three-Phase OH 400A 4-Wire 277/480 Volts Wye

LEFT SIDE UNDERGROUND ENTRANCE

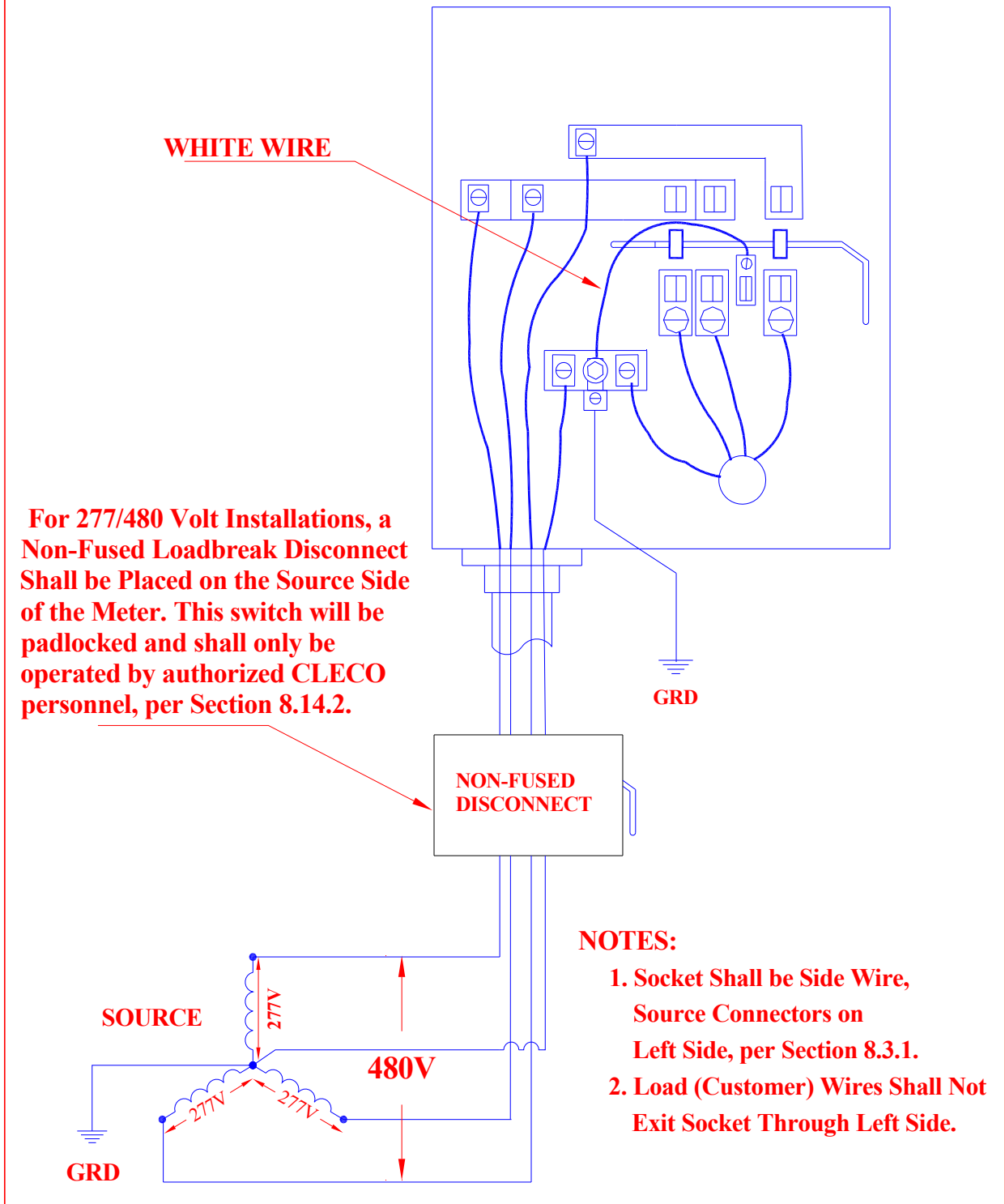

DRAWN BY:	trh	DATE:	6/5/06	THREE PHASE UNDERGROUND 400 AMP 4-WIRE 277/480 VOLTS WYE	FILE NAME:	I-12
REVISION:	1/18/24	REV BY:	MLM		SCALE:	
ELECTRIC SERVICE STANDARDS				Cleco Power LLC PINEVILLE, LOUISIANA	SH. <u>1</u> OF	<u>1</u> SHEETS

Fig. I-12 Three-Phase UG 400A 4-Wire 277/480 Volts Wye

APPENDIX II
OVERHEAD DRAWINGS

This Page Left Blank Intentionally

ELECTRIC SERVICE STANDARDS

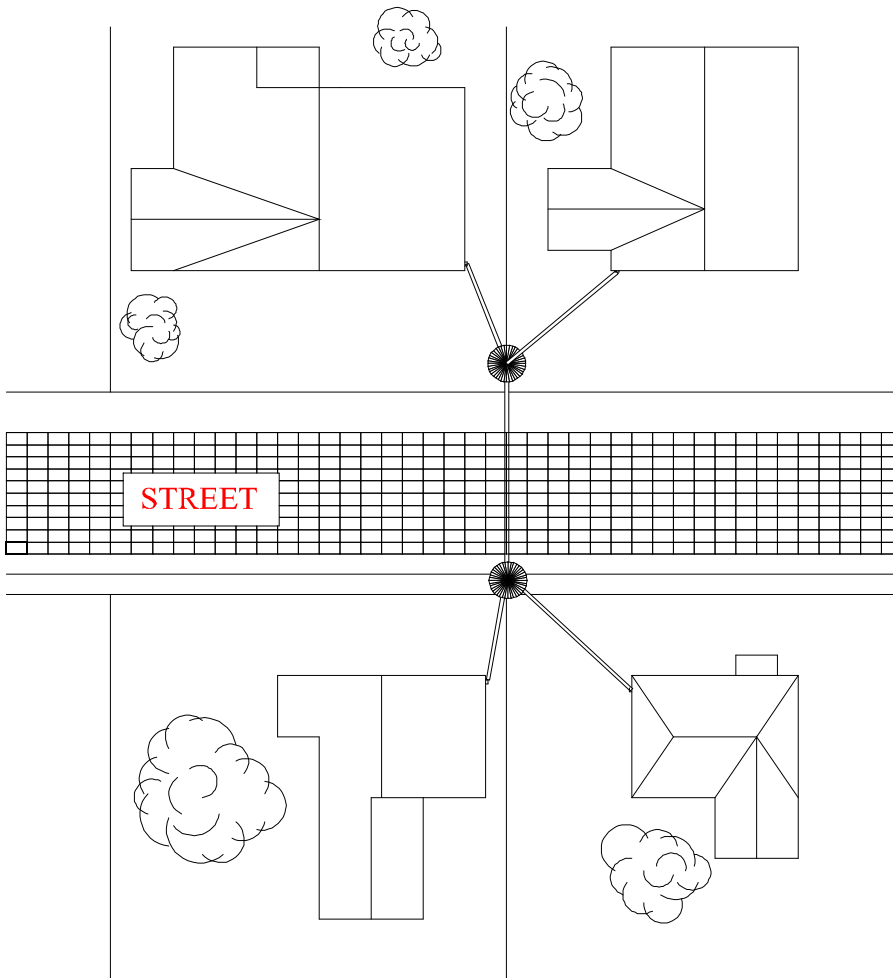

**NOTE: CUSTOMER WILL BE BILLED FOR SERVICE TO OTHER
THAN NEAREST REASONABLE SUPPLY POINT.**

DRAWN BY:	rjl	DATE:	1/4/2002	TYPICAL SERVICE LINE ARRANGEMENT	FILE NAME:	II-1
REVISION:	6/5/06	REV BY:	trh		SCALE:	SH. 1 OF
ELECTRIC SERVICE STANDARDS				Cleco Power LLC	1 SHEETS	
				PINEVILLE, LOUISIANA		

Fig. II-1 Typical Service Line Arrangement 1

ELECTRIC SERVICE STANDARDS

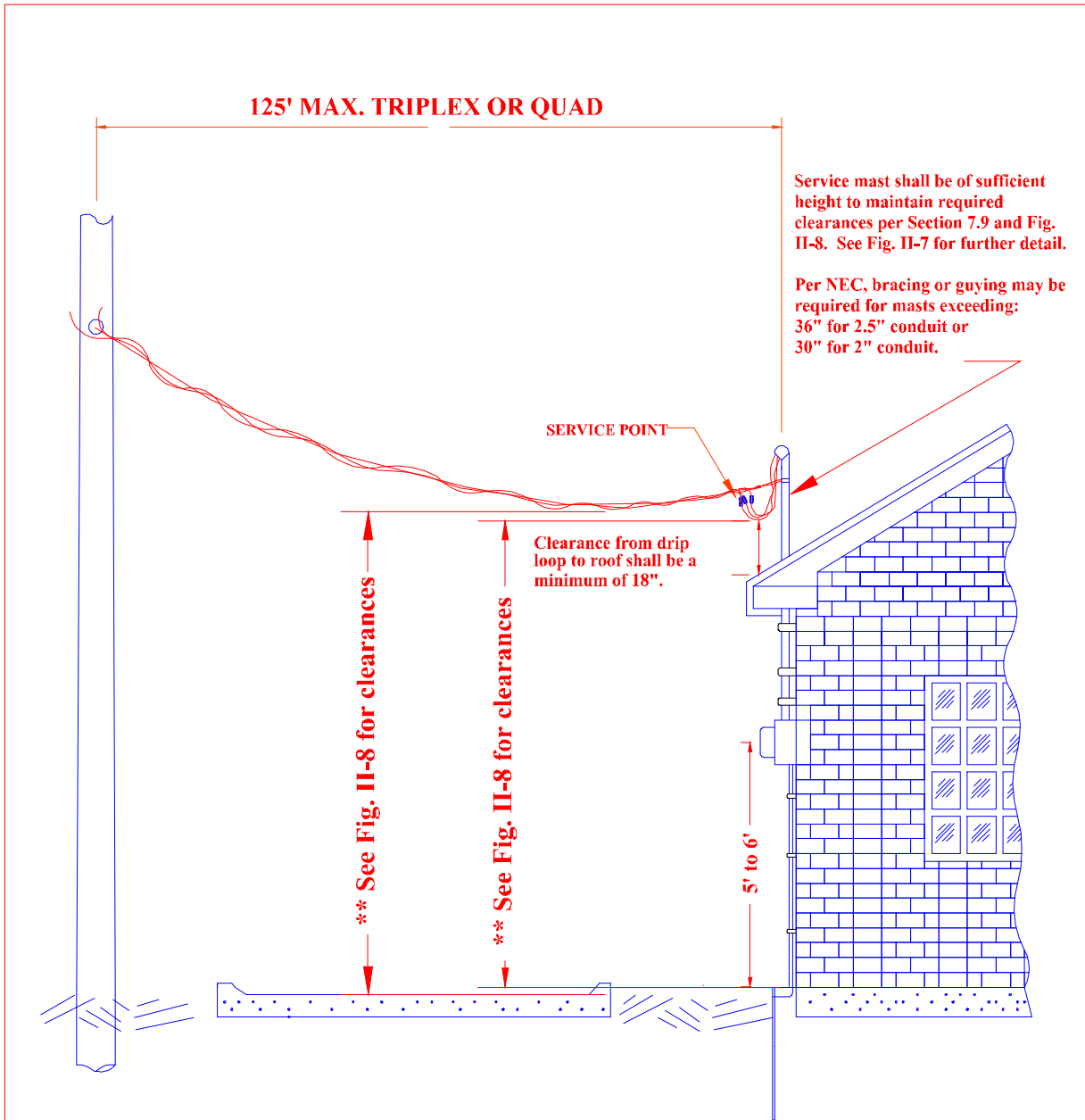

NOTES:

1. Means of disconnection may be located inside or outside the building or structure.
2. If it is impossible to achieve required clearances per Fig. II-8, call Cleco at 1-800-622-6537.
3. The above clearances are minimum requirements for connection to the Cleco system.
If local codes differ, the more stringent requirements shall rule.
4. ** For purposes of these clearances, any vehicle which exceeds eight (8) feet in height is defined as a truck.

DRAWN BY:	trh	DATE:	8/9/05	ILLUSTRATION OF CLEARANCES SERVICE UP TO 600 VOLTS PHASE TO GROUND	FILE NAME:	II-3
REVISION:	8/29/08	REV BY:	trh		SCALE:	
ELECTRIC SERVICE STANDARDS				Cleco Power LLC	SH. <u> 1 </u> OF	
				PINEVILLE, LOUISIANA	<u> 1 </u> SHEETS	

Fig. II-3 Illustration of Clearances Less Than 600V Phase-to-Ground

ELECTRIC SERVICE STANDARDS

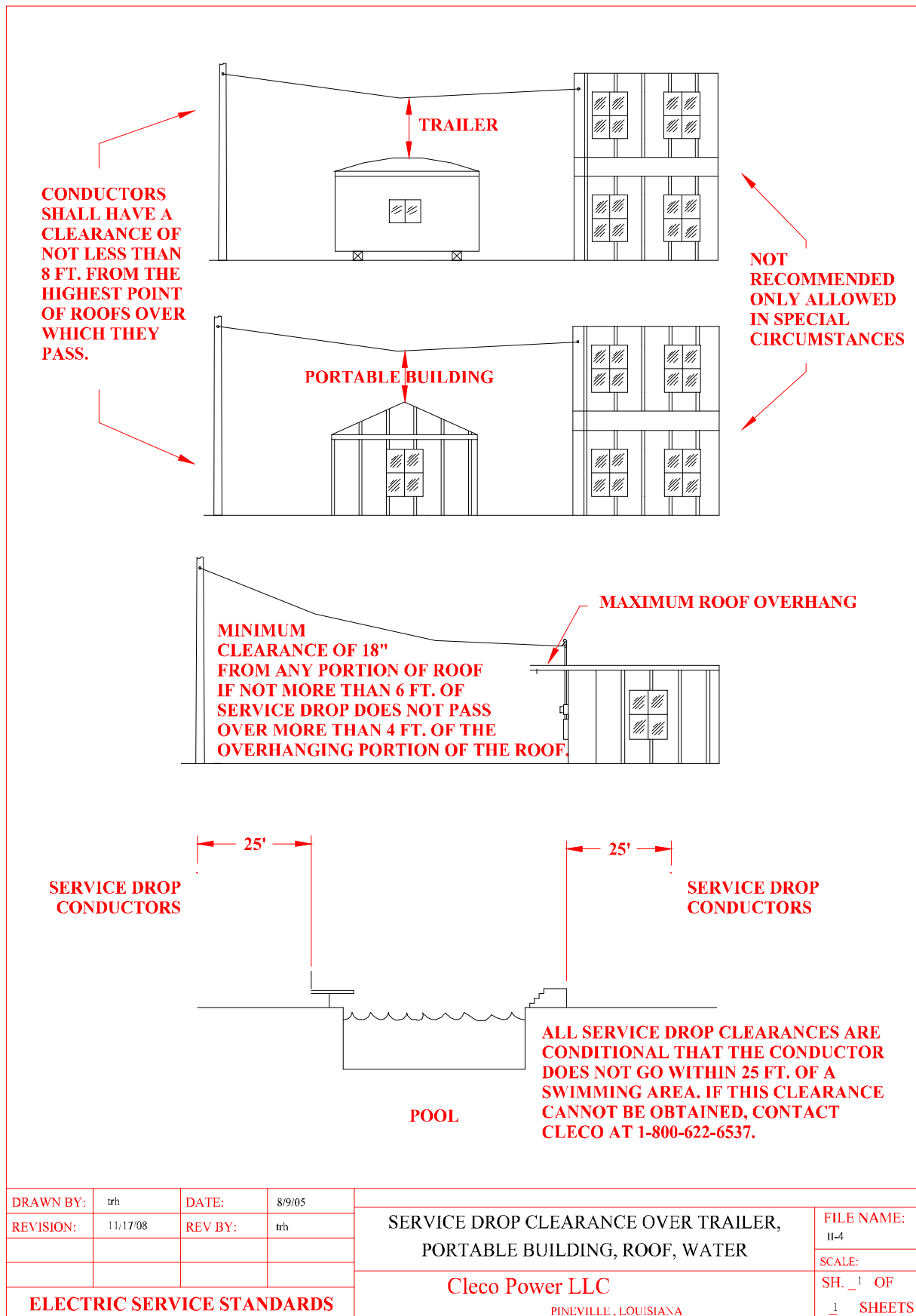

Fig. II-4 Illustration of Service Drop Clearance Over Trailer, etc.

ELECTRIC SERVICE STANDARDS

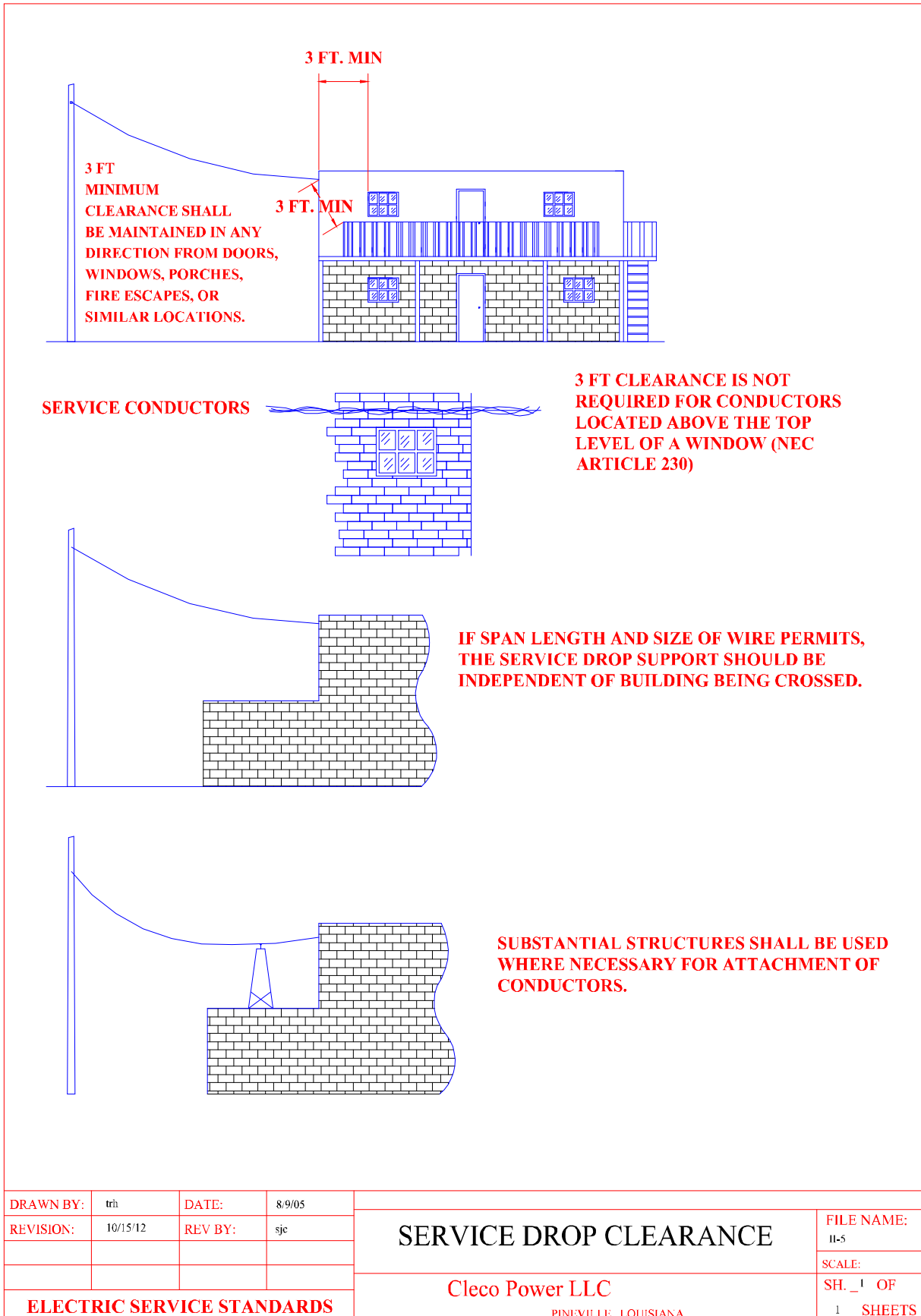
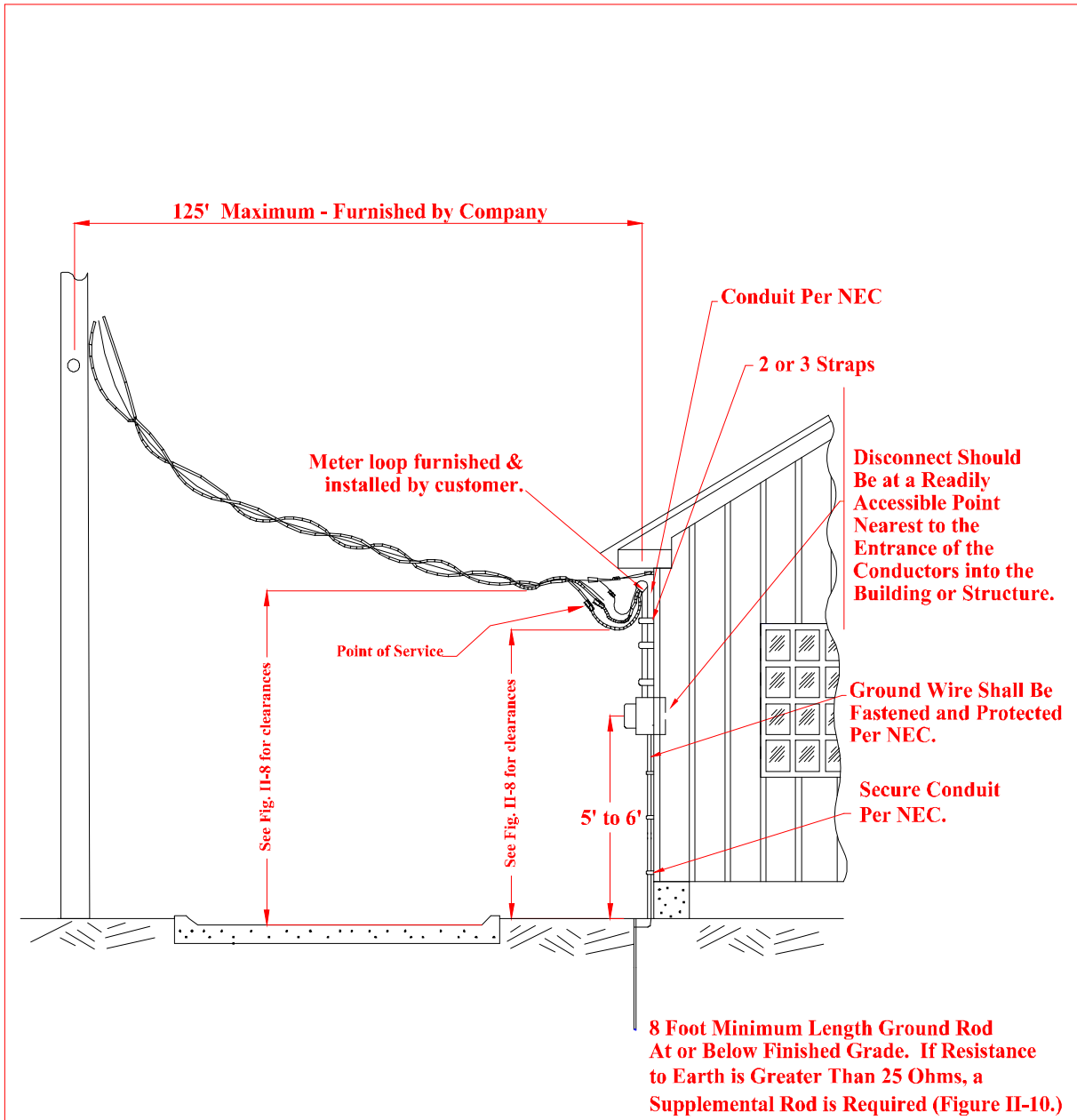

Fig. II-5 Illustration of Service Drop Clearance Over Buildings

ELECTRIC SERVICE STANDARDS



NOTES:

1. Service voltages shall be 120/240 V single-phase, 120/240V or 120/208V three phase.
2. Meter socket furnished and installed by customer.
3. Meter furnished and installed by Cleco.
4. Disconnecting means may be installed inside or outside of the building structure, per NEC.

DRAWN BY:	trh	DATE:	8/12/05	TYPICAL OVERHEAD SERVICE INSTALLATION	FILE NAME:	II-6
REVISION:	11/7/12	REV BY:	sjc		SCALE:	
ELECTRIC SERVICE STANDARDS				Cleco Power LLC	SH. <u>1</u> OF	
				<small>PINEVILLE, LOUISIANA</small>	<u>1</u> SHEETS	

Fig. II-6 Typical Overhead Service Installation

ELECTRIC SERVICE STANDARDS

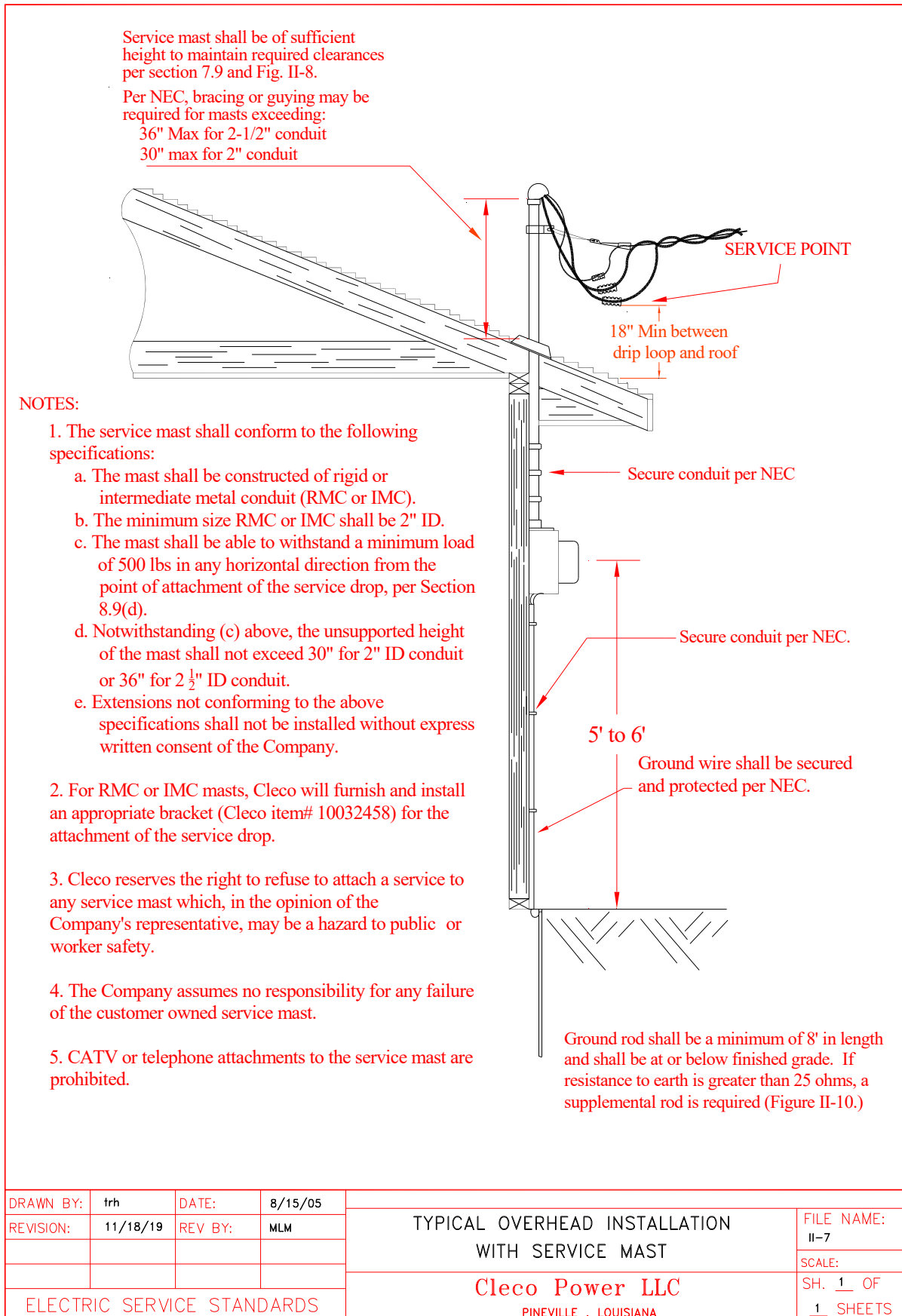

DRAWN BY:	trh	DATE:	8/15/05	TYPICAL OVERHEAD INSTALLATION WITH SERVICE MAST Cleco Power LLC PINEVILLE , LOUISIANA	FILE NAME:	II-7
REVISION:	11/18/19	REV BY:	MLM		SCALE:	
ELECTRIC SERVICE STANDARDS					SH. <u>1</u> OF	<u>1</u> SHEETS

Fig. II-7 Typical Overhead Service Mast Installation

ELECTRIC SERVICE STANDARDS

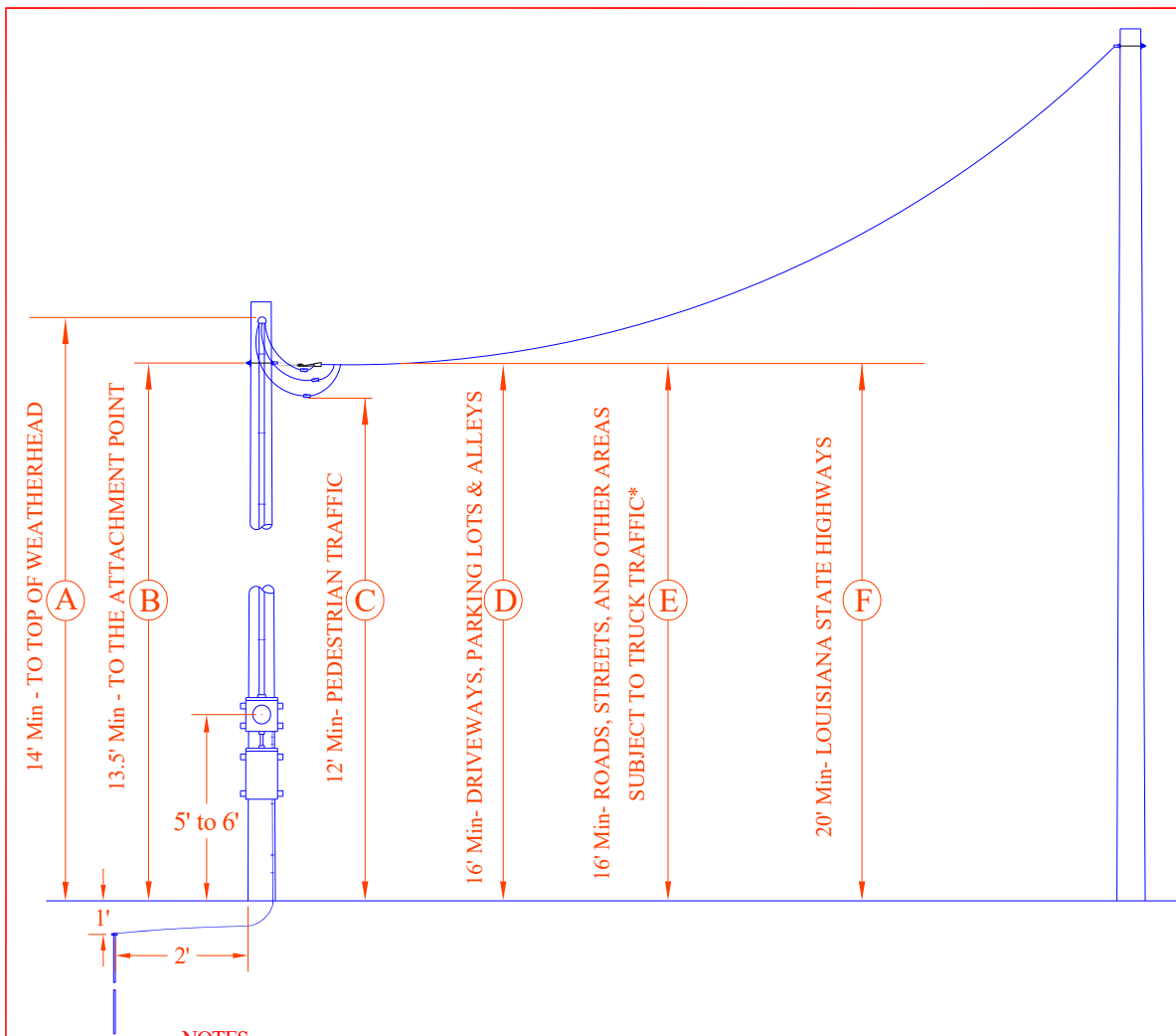

Fig. II-10

NOTES:

- (A) 14' Min clearance to the top of weatherhead. Additional pole height may be required to meet clearance per Section 7.9
- (B) 13.5' Min clearance to the customer installed minimum 1/2" eye bolt with 2"x2" square washer. Additional pole height may be required to meet clearance per Section 7.9
- (C) 12' Min clearance for areas subject to pedestrian or restricted traffic only. Additional pole height may be required to meet clearance per Section 7.9
- (D) 16' Min clearance over Driveways, Parking Lots and Alleys. Where this construction crosses over or runs along alleys, driveways, or parking lots NOT SUBJECT TO TRUCK TRAFFIC this clearance may be reduced to 15'.
- (E) 16' Min clearance over Roads, Streets, and other areas SUBJECT TO TRUCK TRAFFIC.
- (F) 20' Min from clearance over Louisiana State Highways per LaDOTD Permits.

* For the purpose of these notes, trucks are defined as any vehicle exceeding 8' in height.

DRAWN BY:	trh	DATE:	8/15/05	0-750V SECONDARY OVERHEAD CLEARANCES TO METER POLE: PERMANENT OR TEMPORARY	FILE NAME:
REVISION:	05/29/15	REV BY:	DJC		II-8
ELECTRIC SERVICE STANDARDS				Cleco Power LLC PINEVILLE , LOUISIANA	SCALE:
					SH. <u>1</u> OF <u> </u>
					<u>1</u> SHEETS

Fig. II-8 0-750V Secondary OH Clearances

ELECTRIC SERVICE STANDARDS

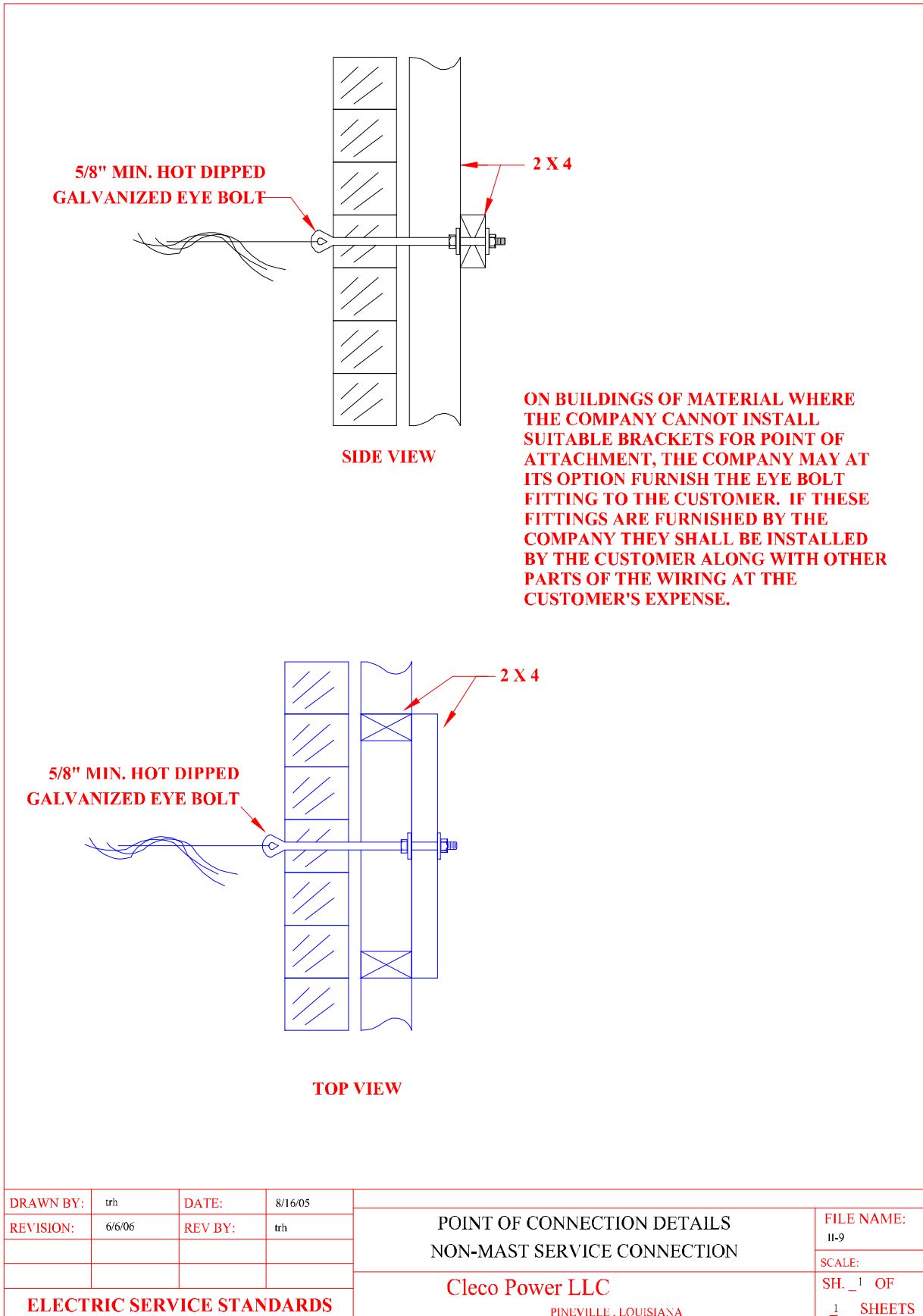
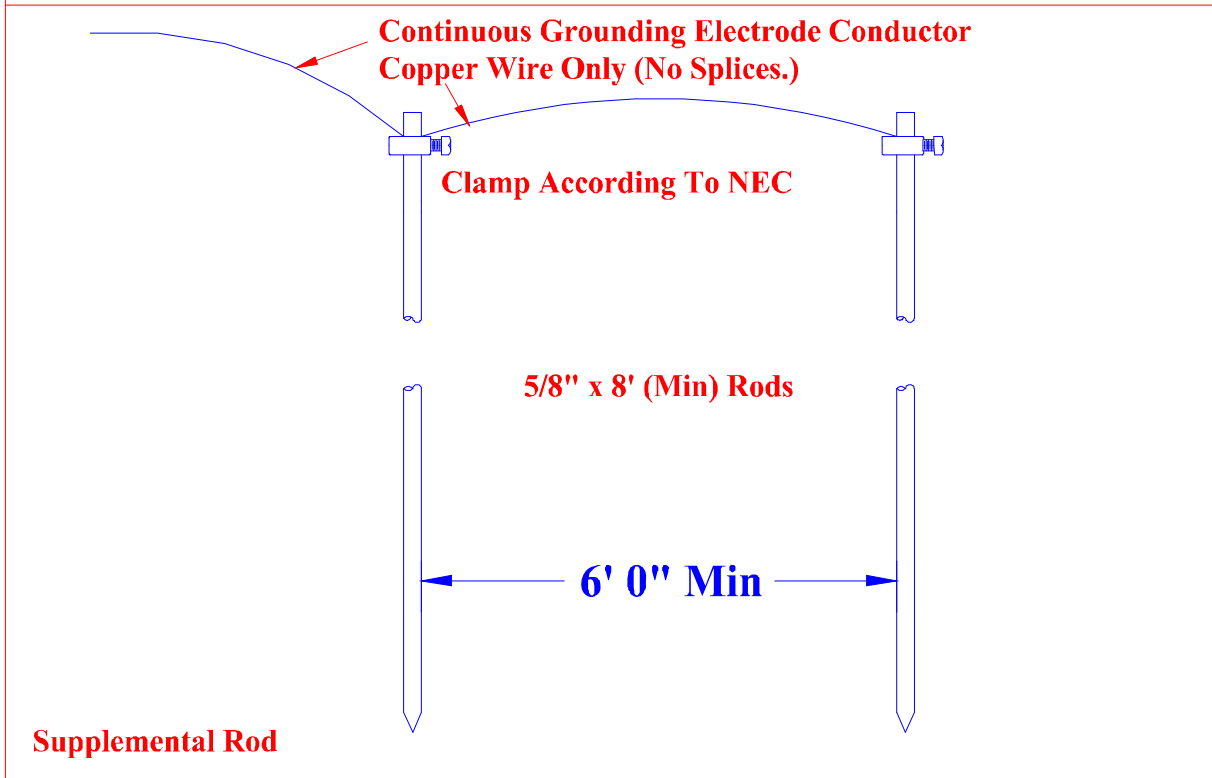
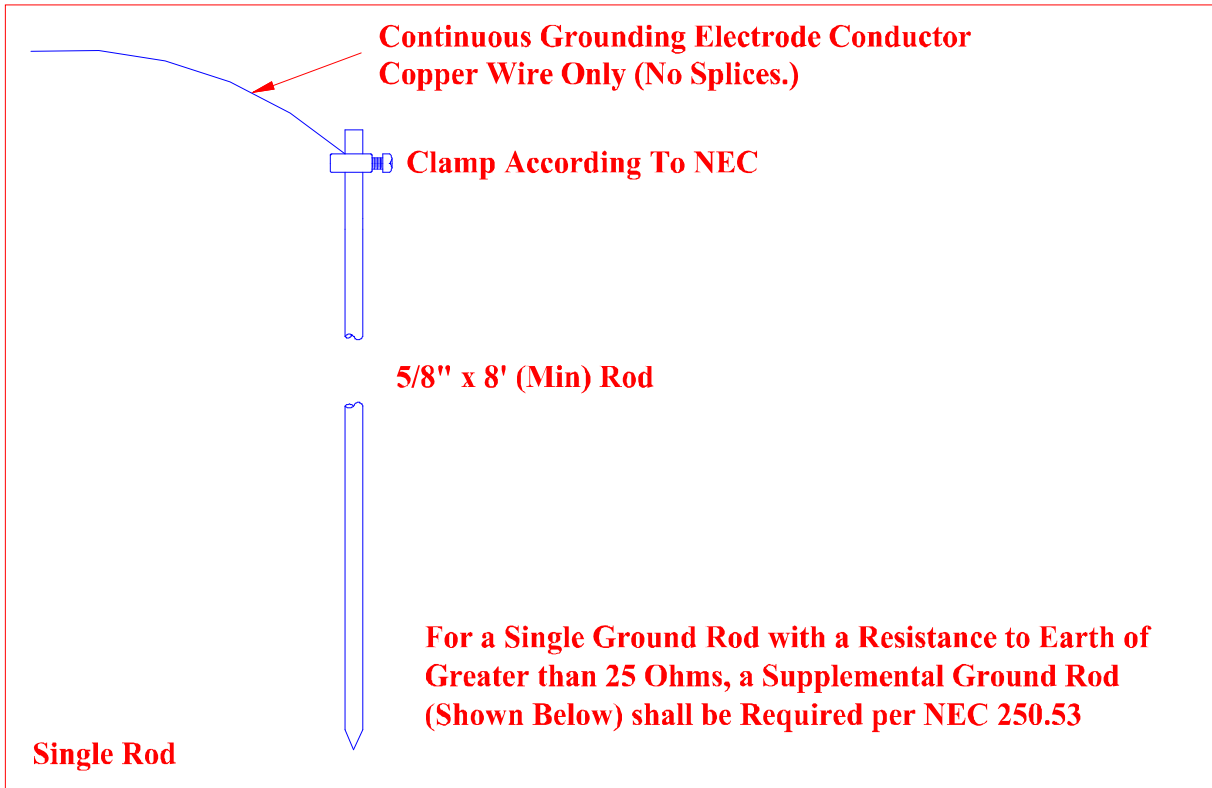

Fig. II-9 Point Of Connection Details: Non-Mast Connected Services

ELECTRIC SERVICE STANDARDS



DRAWN BY:	trh	DATE:	10/7/12	APPROVED GROUND ROD(S)	FILE NAME:	II-10
REVISION:	11/7/12	REV BY:	sjc		SCALE:	
ELECTRIC SERVICE STANDARDS					Cleco Power LLC <small>PINEVILLE, LOUISIANA</small>	SH. <u>1</u> OF <u>1</u> SHEETS

Fig. II-10 Cleco Approved Ground Rod

ELECTRIC SERVICE STANDARDS

NOTES:

1. Pole shall be of adequate strength to support line strain and lineman.
Minimum size pole shall be a 20 foot class 7.
2. Any temporary service considered inadequate will not be connected.
3. Customer shall furnish and install meter socket.
4. Cleco shall furnish and install meter.
5. Spans longer than 85 feet may require bracing or guying. (See fig. II-12)
6. If resistance to earth is greater than 25 ohms, a supplemental ground rod is required (fig. II-10)

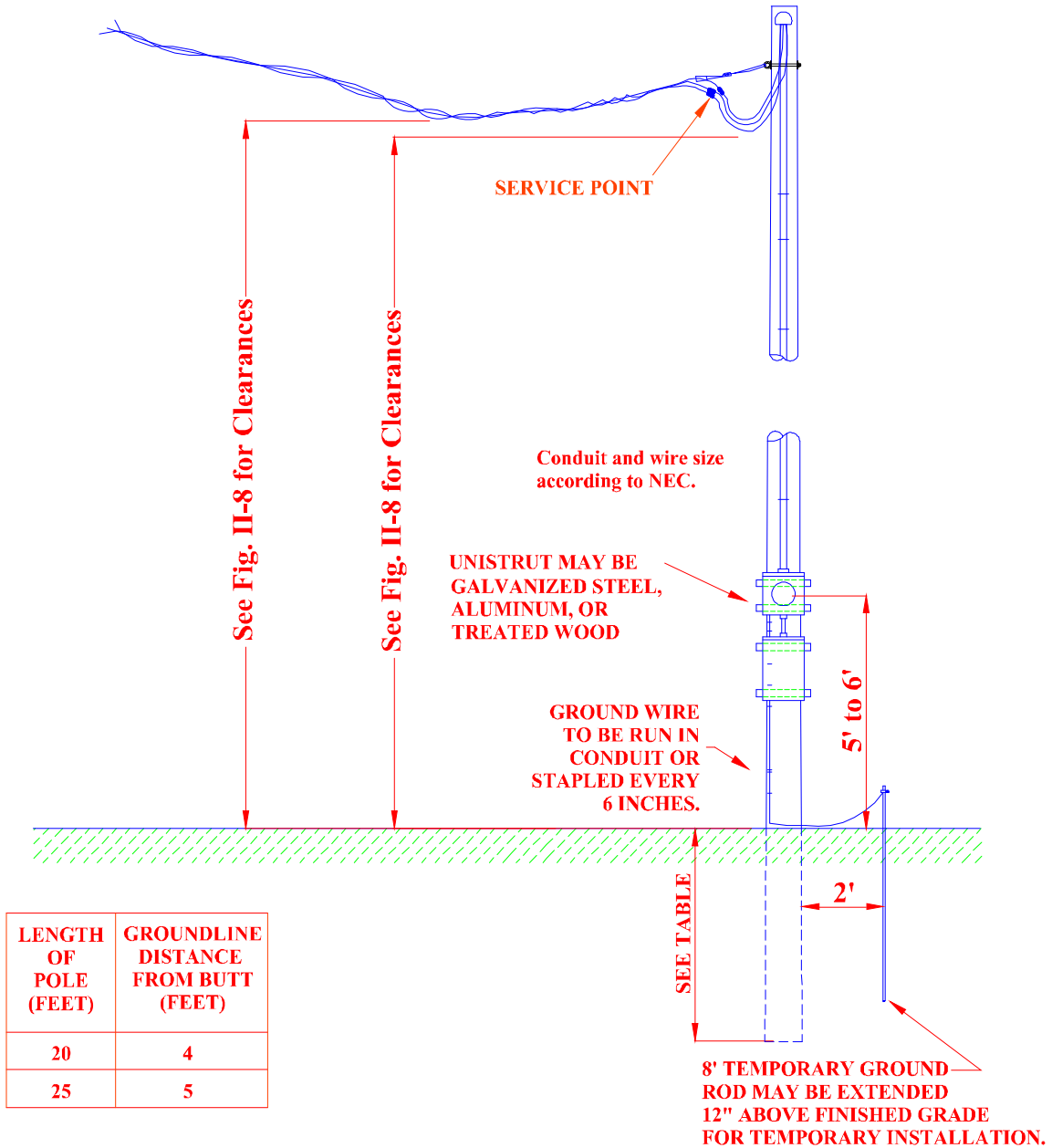

DRAWN BY:	trh	DATE:	8/16/05	TEMPORARY SERVICE UNBRACED POLE	FILE NAME:	II-11
REVISION:	11/8/12	REV BY:	sjc		SCALE:	
Cleco Power LLC					SH. <u>1</u> OF	
ELECTRIC SERVICE STANDARDS				PINEVILLE, LOUISIANA	<u>1</u> SHEETS	

Fig. II-11 Illustration of Temporary Service, Unbraced Pole

ELECTRIC SERVICE STANDARDS

Notes:

1. Temporary service structures shall be strong enough to support the stress of service wires and attached equipment.
2. Any temporary service considered inadequate by Cleco will not be connected.
3. If service wire is larger than 1/0 ACSR, timber size shall be 6" by 6" (nominal).
4. All customer wiring shall comply with NEC.

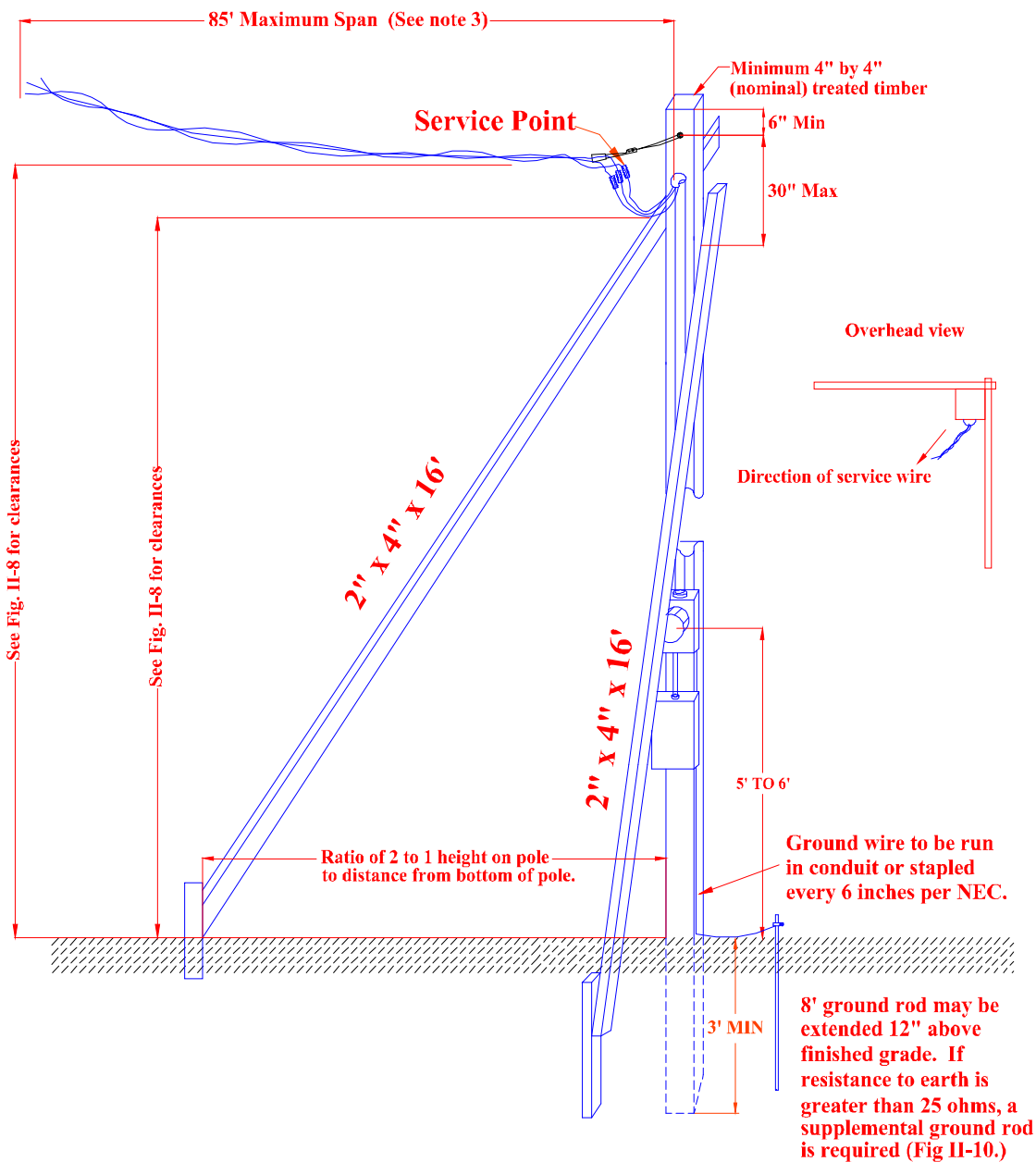

DRAWN BY:	trh	DATE:	8/16/05	TEMPORARY SERVICE BRACED POLE	FILE NAME:	II-12
REVISION:	11/8/12	REV BY:	sjc		SCALE:	
ELECTRIC SERVICE STANDARDS				Cleco Power LLC	SH. <u>1</u> OF <u>1</u> SHEETS	
				PINEVILLE, LOUISIANA		

Fig. II-12 Illustration of Temporary Service, Braced Pole

ELECTRIC SERVICE STANDARDS

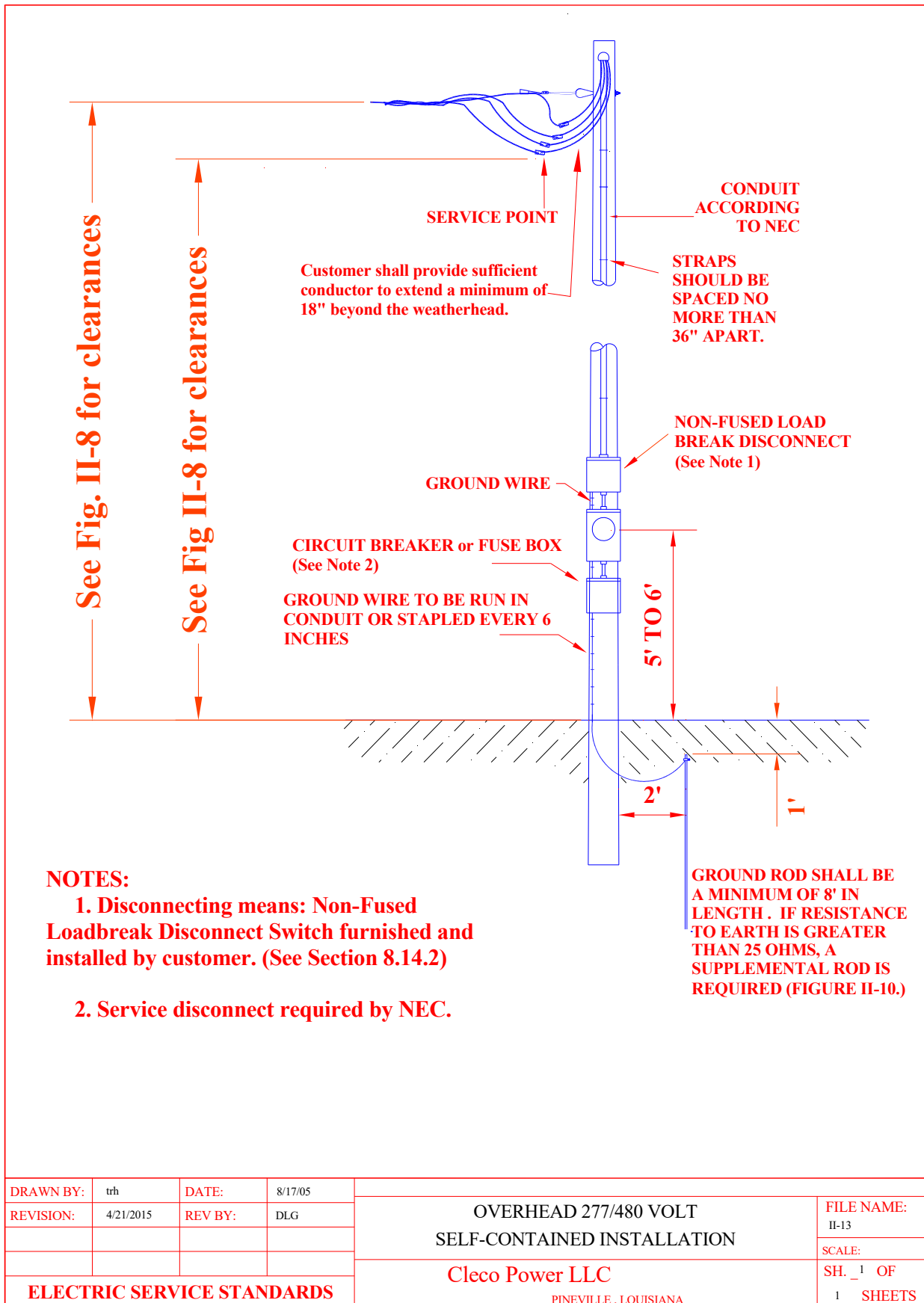
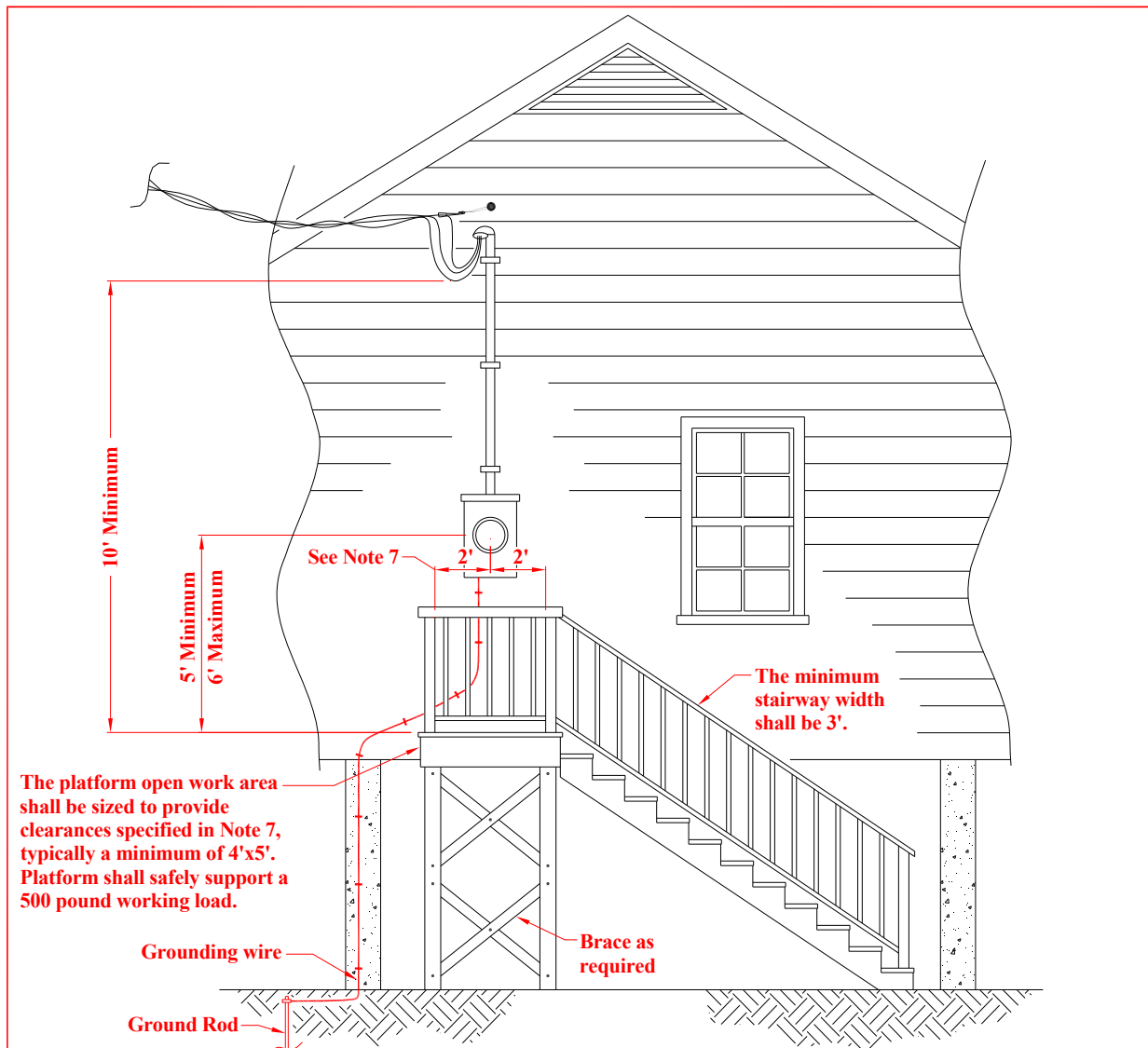

Fig. II-13 277/480 Volt Overhead Self-Contained Installation

ELECTRIC SERVICE STANDARDS



NOTES:

1. Any customer provided facilities shall comply with all Cleco Electric Service Standards and all state and local building codes.
2. Platforms shall not be allowed on new construction and will only be approved for existing meters installations where the facility is being raised. The installation of elevated platforms must be approved by Cleco prior to construction. For all new construction the meter must be installed on a normal path of ingress/egress to the structure.
3. Cleco reserves the right to inspect all customer owned platform facilities. If the platform is determined to be substandard and/or unsafe the customer will be required to correct all deficiencies.
4. Both hand railings and stair railings shall be required for all platforms higher than 3' above ground level.
5. The platform and stairs shall be constructed of weather resistant materials suitable for outdoor applications. All exposed wood shall be pressure treated and sealed or treated to prevent premature deterioration.
6. Stair tread and riser dimensions shall meet state and local building code requirements. The maximum riser height shall be 7.5" and the minimum tread width shall be 10.5".
7. A minimum of 4 feet clear working space shall be provided between the front side of the meter and any opposing wall or railing. A minimum of 2 feet of clear working space shall be provided on each side of the meter centerline. These clearances shall also apply to any other equipment (i.e. generators, air conditioners) installed on the platform.

DRAWN BY:	WDH	DATE:	04/02/2013	METER ACCESS PLATFORM FOR RAISING OF EXISTING METERS ONLY	FILE NAME:	II-14
REVISION:		REV BY:			SCALE:	
ELECTRIC SERVICE STANDARDS				Cleco Power LLC	SH. <u>1</u> OF	1 SHEETS
				PINEVILLE, LOUISIANA		

Fig. II-14 Meter Access Platform for Raising of Existing Meters Only

This Page Left Blank Intentionally

APPENDIX III

MOBILE HOME, MARINAS AND UNDERGROUND
SERVICES

This Page Left Blank Intentionally

ELECTRIC SERVICE STANDARDS

NOTES:

1. Pole shall be adequate to support conductor tensions and lineman;
 *Minimum size Round Wood Pole shall be a 20-foot/ Class-6.
 **6" x 6" Timber not appropriate for Stand-Alone application and should have down guy-See Note 4.
2. Customer shall furnish and install meter socket.
3. CLECO shall furnish meter.
4. For services longer than 85-feet and a 6"x6" Timber, customer shall provide and install anchor and down guy. Guy bracket shall be attached opposite (180°) to service wire tension. Approved to use service wire eyebolt as top guy mounting bolt. Guy attachment/ anchor ratio should be not less than 2:1 (1:1 ratio is preferred).

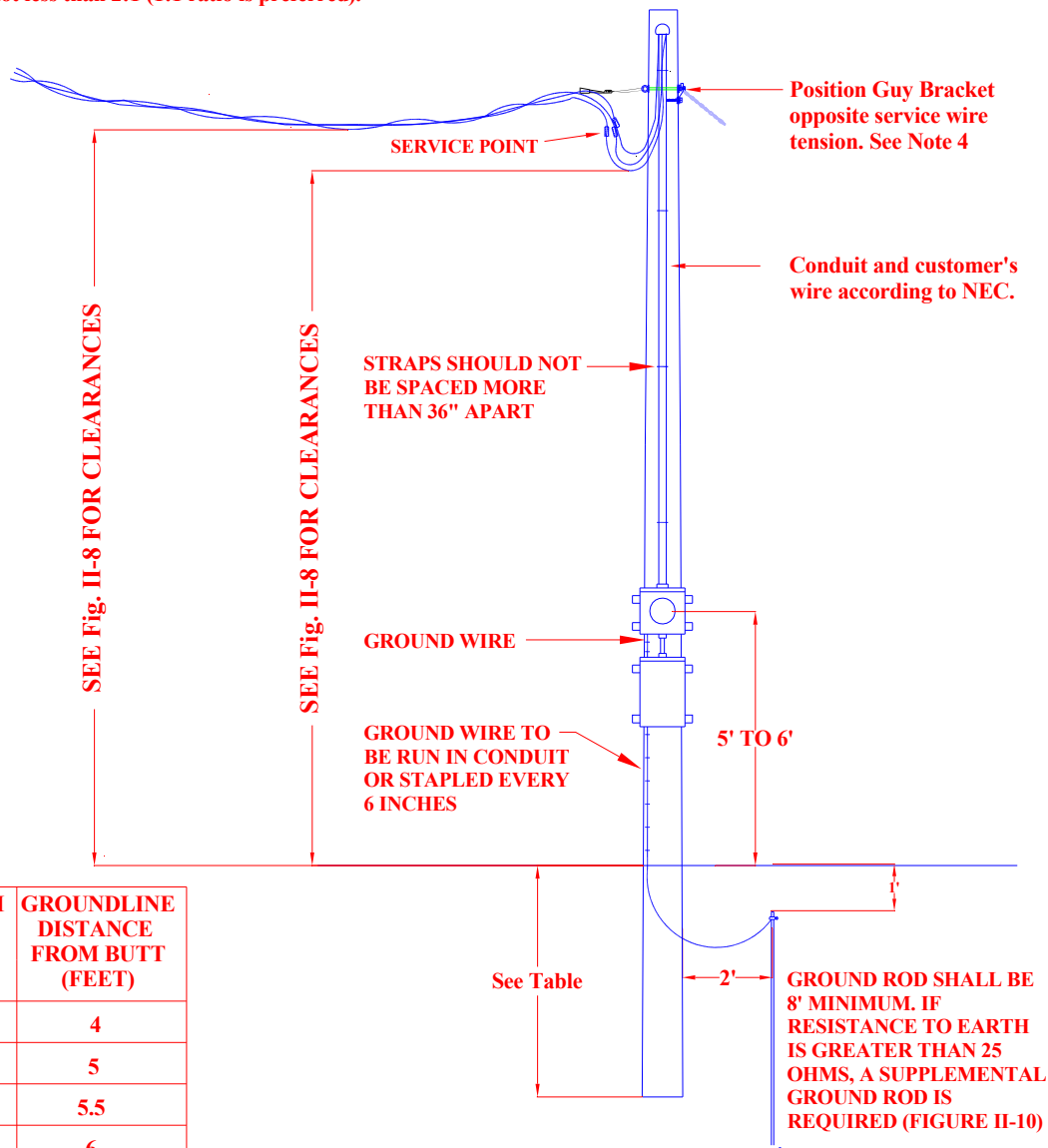

LENGTH OF POLE (FEET)	GROUNDLINE DISTANCE FROM BUTT (FEET)
20	4
25	5
30	5.5
35	6
40	6

DRAWN BY:	trh	DATE:	8/18/05	GENERAL SERVICE POLE	FILE NAME:	III-1
REVISION:	04/17/15	REV BY:	DJC		SCALE:	
ELECTRIC SERVICE STANDARDS					Cleco Power LLC	SH. <u> 1 </u> OF
				PINEVILLE, LOUISIANA	<u> 1 </u> SHEETS	

Fig. III-1 General Service Pole

ELECTRIC SERVICE STANDARDS

NOTES:

1. Pole shall be adequate to support conductor tensions and lineman;
 *Minimum size Round Wood Pole shall be a 20-foot/ Class-6.
 **6" x 6" Timber not appropriate for Stand-Alone application and should have down guy-See Note 4.
2. Customer shall furnish and install meter socket.
3. CLECO shall furnish meter.
4. For services longer than 85-feet and a 6"x6" Timber, customer shall provide and install anchor and down guy. Guy bracket shall be attached opposite (180°) to service wire tension. Approved to use service wire eyebolt as top guy mounting bolt. Guy attachment/ anchor ratio should be not less than 2:1 (1:1 ratio is preferred).

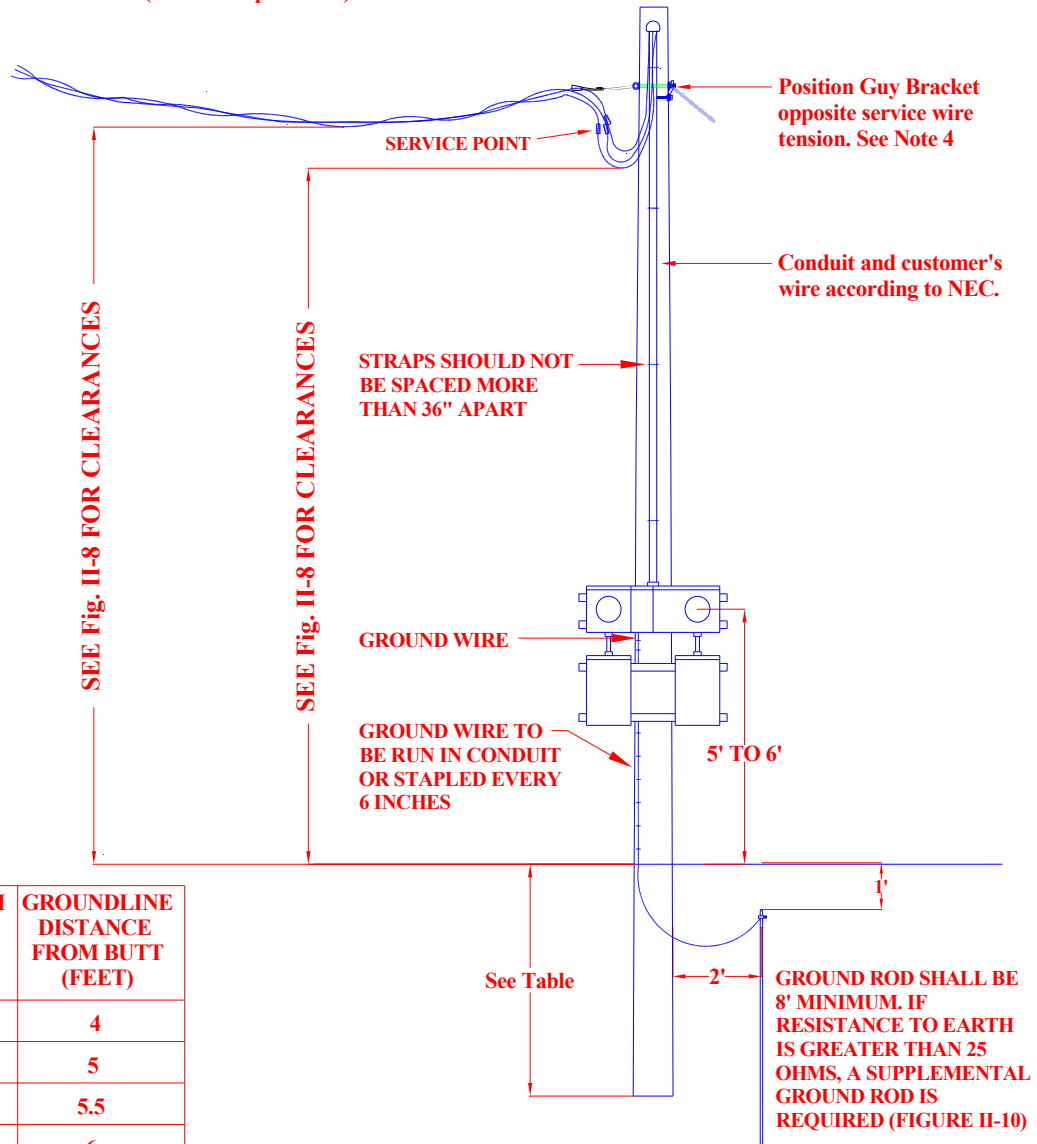

LENGTH OF POLE (FEET)	GROUNDLINE DISTANCE FROM BUTT (FEET)
20	4
25	5
30	5.5
35	6
40	6

DRAWN BY:	trh	DATE:	8/18/05	DUAL-GENERAL SERVICE POLE	FILE NAME:	III-2
REVISION:	04/17/15	REV BY:	DJC		SCALE:	
ELECTRIC SERVICE STANDARDS				Cleco Power LLC	SH. <u>1</u> OF	
				PINEVILLE, LOUISIANA	<u>1</u> SHEETS	

Fig. III-2 Dual General Service Pole

ELECTRIC SERVICE STANDARDS

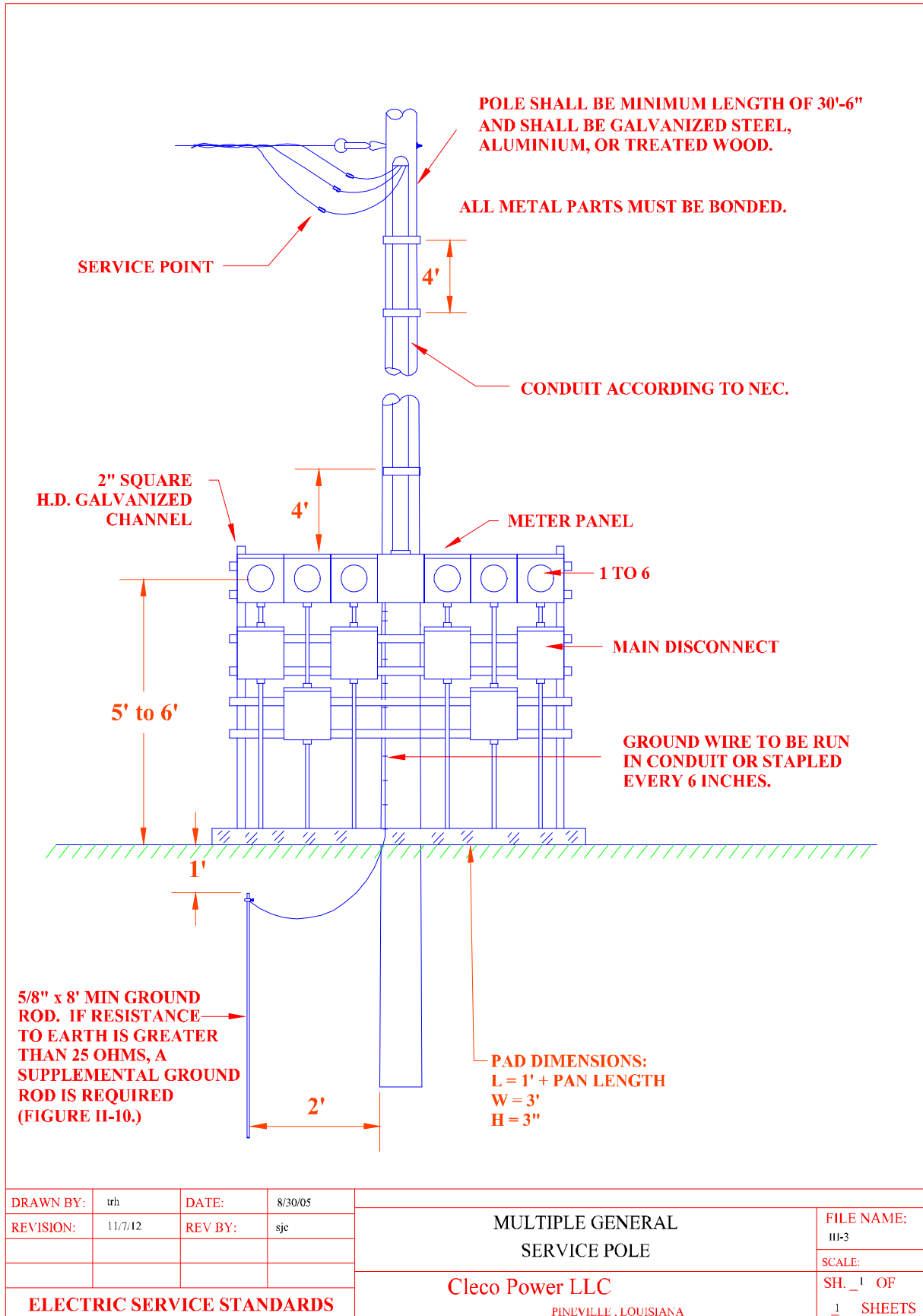

Fig. III-3 Multiple General Service Pole

ELECTRIC SERVICE STANDARDS

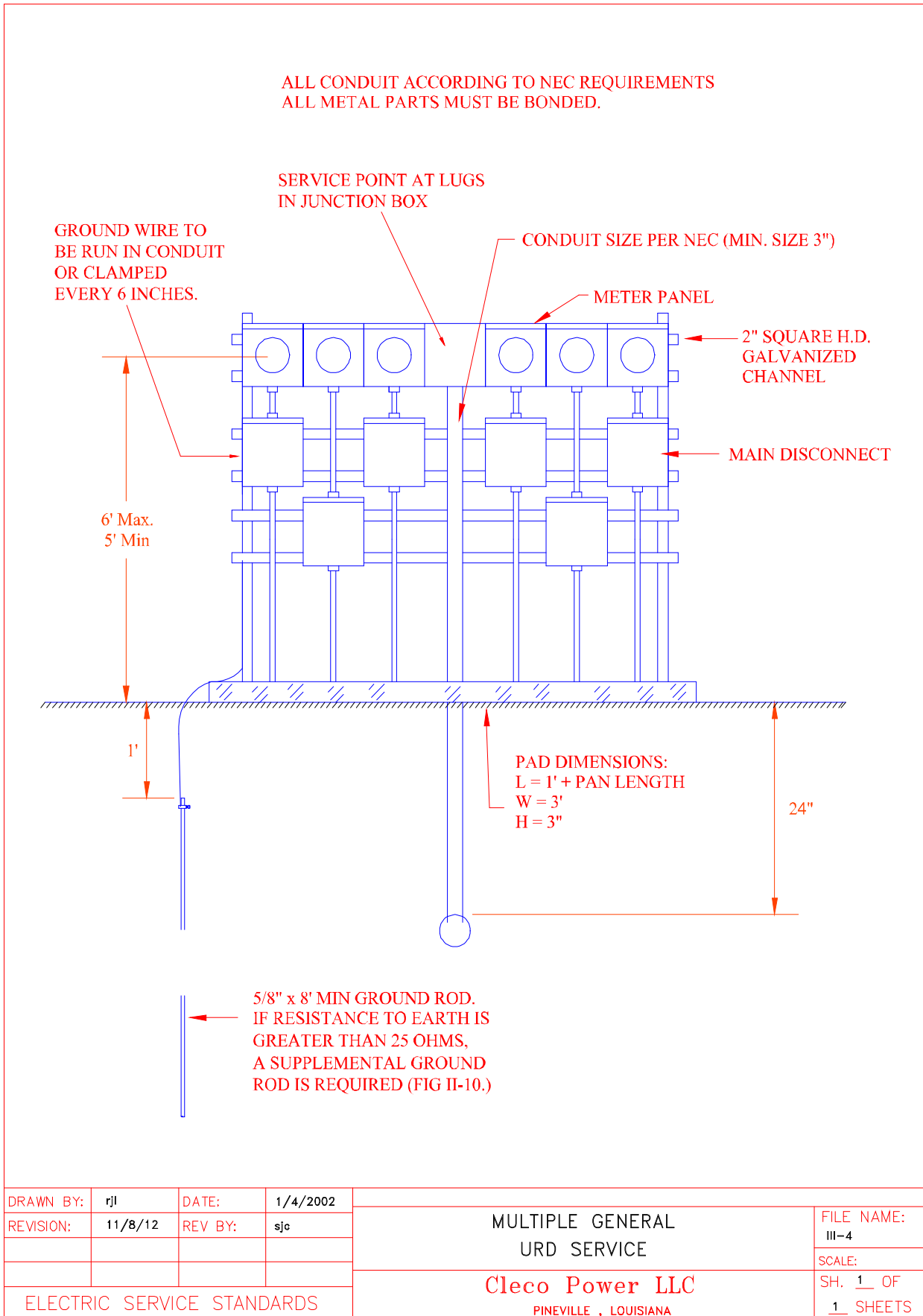
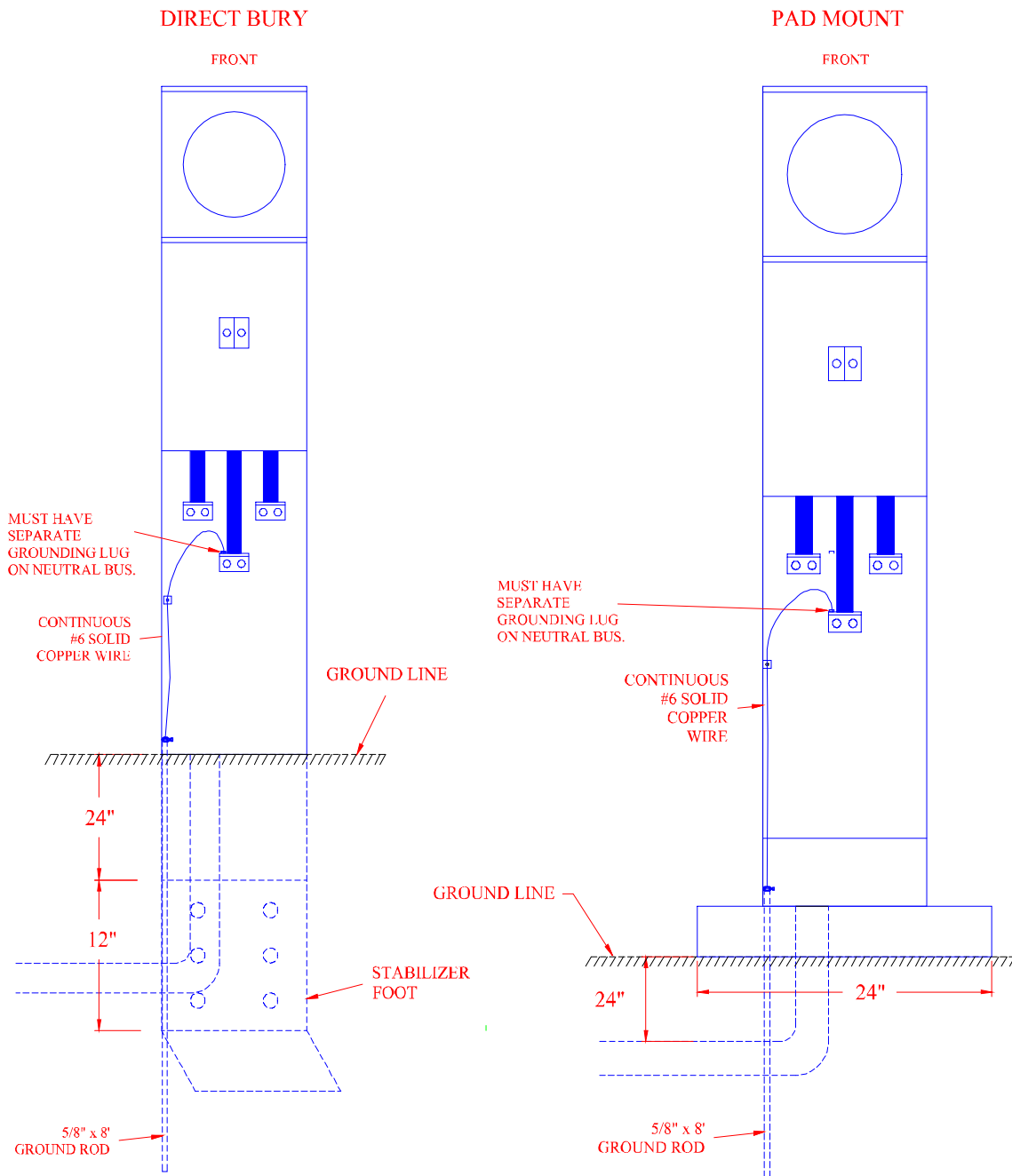

Fig. III-4 Multiple General URD Service

ELECTRIC SERVICE STANDARDS

MOBILE HOME 200 AMP SINGLE METER PEDESTAL INSTALLATION



- NOTE: 1. Ground rod must be installed before meter centers.
 2. Ground rod must be connected to neutral bus.
 3. If resistance to earth is greater than 25 ohms, a supplemental ground rod is required (Fig II-10.)

DRAWN BY:	rjl	DATE:	1/4/2002	MOBILE HOME SINGLE METER PEDESTAL INSTALLATION PAD MOUNT AND DIRECT BURY	FILE NAME:	III-5
REVISION:	11/8/12	REV BY:	sjc		SCALE:	
ELECTRIC SERVICE STANDARDS				Cleco Power LLC		SH. 1 OF
				PINEVILLE, LOUISIANA		1 SHEETS

Fig. III-5 Typical Mobile Home Service Installation

ELECTRIC SERVICE STANDARDS

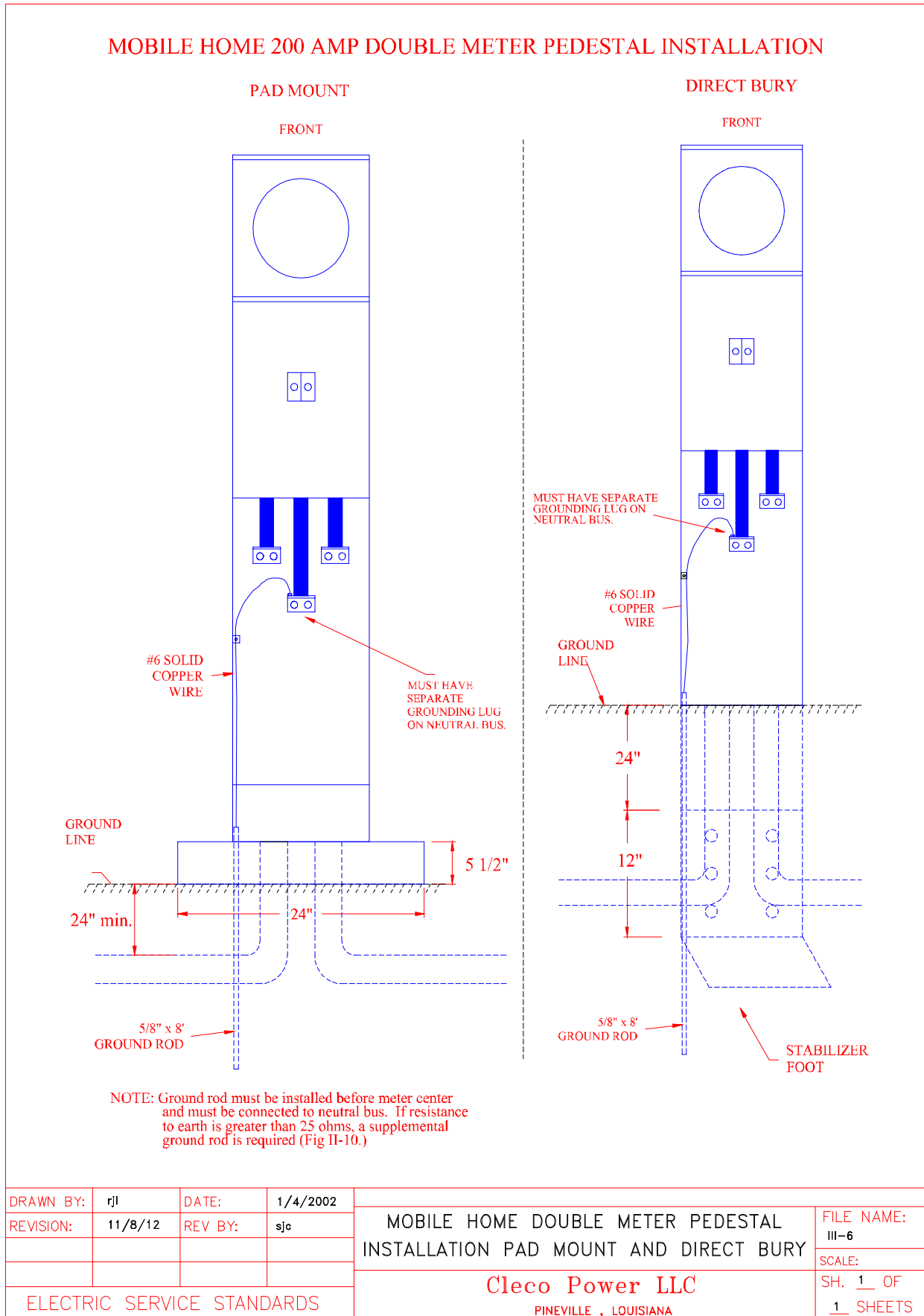
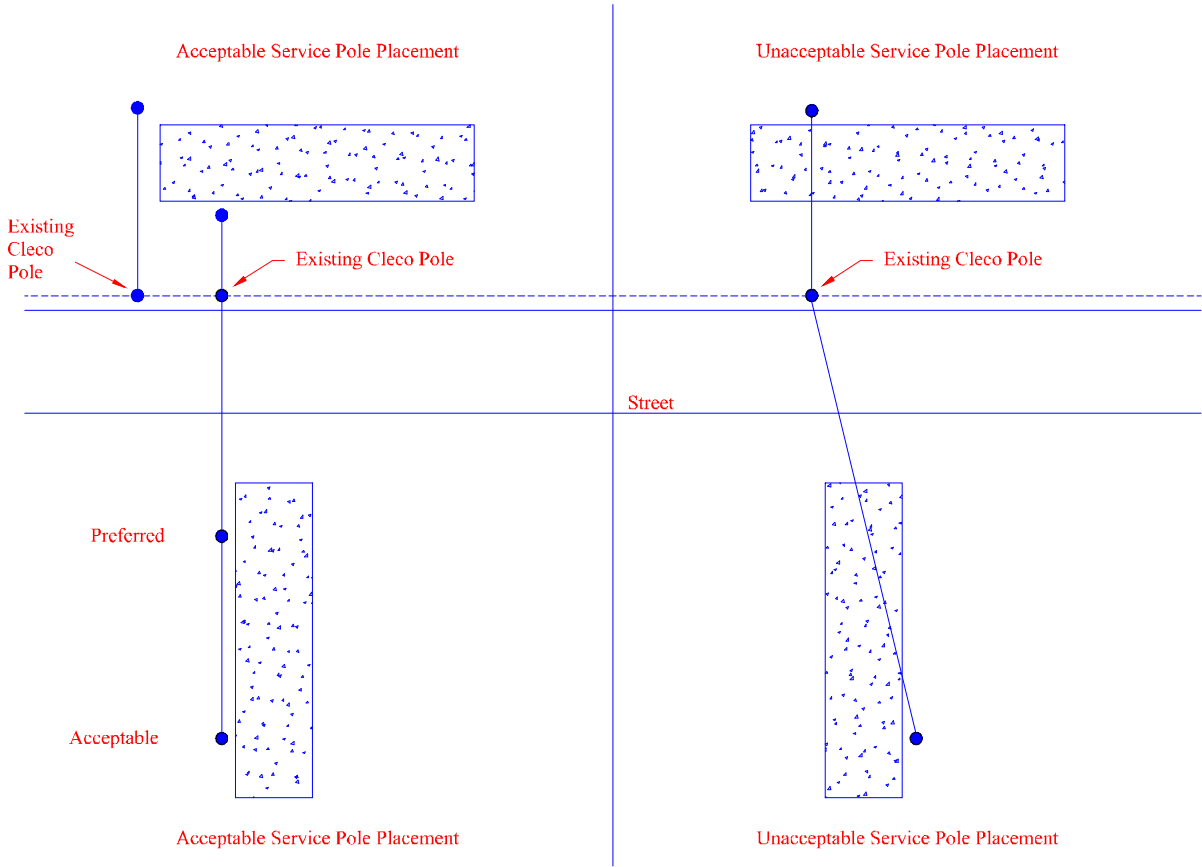

Fig. III-6 Typical Underground Line Arrangement

MOBILE HOME SERVICES



Service Routing & Service Pole Placement

NOTES:

1. Service line should not pass over top of mobile home.
2. Customer will be billed for service to other than nearest reasonable point.

DRAWN BY:	rjl	DATE:	12/21/2001	OVERHEAD MOBILE HOME SERVICE	FILE NAME:
REVISION:	7/7/06	REV BY:	trh		III-7
					SCALE:
ELECTRIC SERVICE STANDARDS				Cleco Power LLC PINEVILLE , LOUISIANA	SH. 1 OF 1 SHEETS

Fig. III-7 Overhead Mobile Home Service

ELECTRIC SERVICE STANDARDS

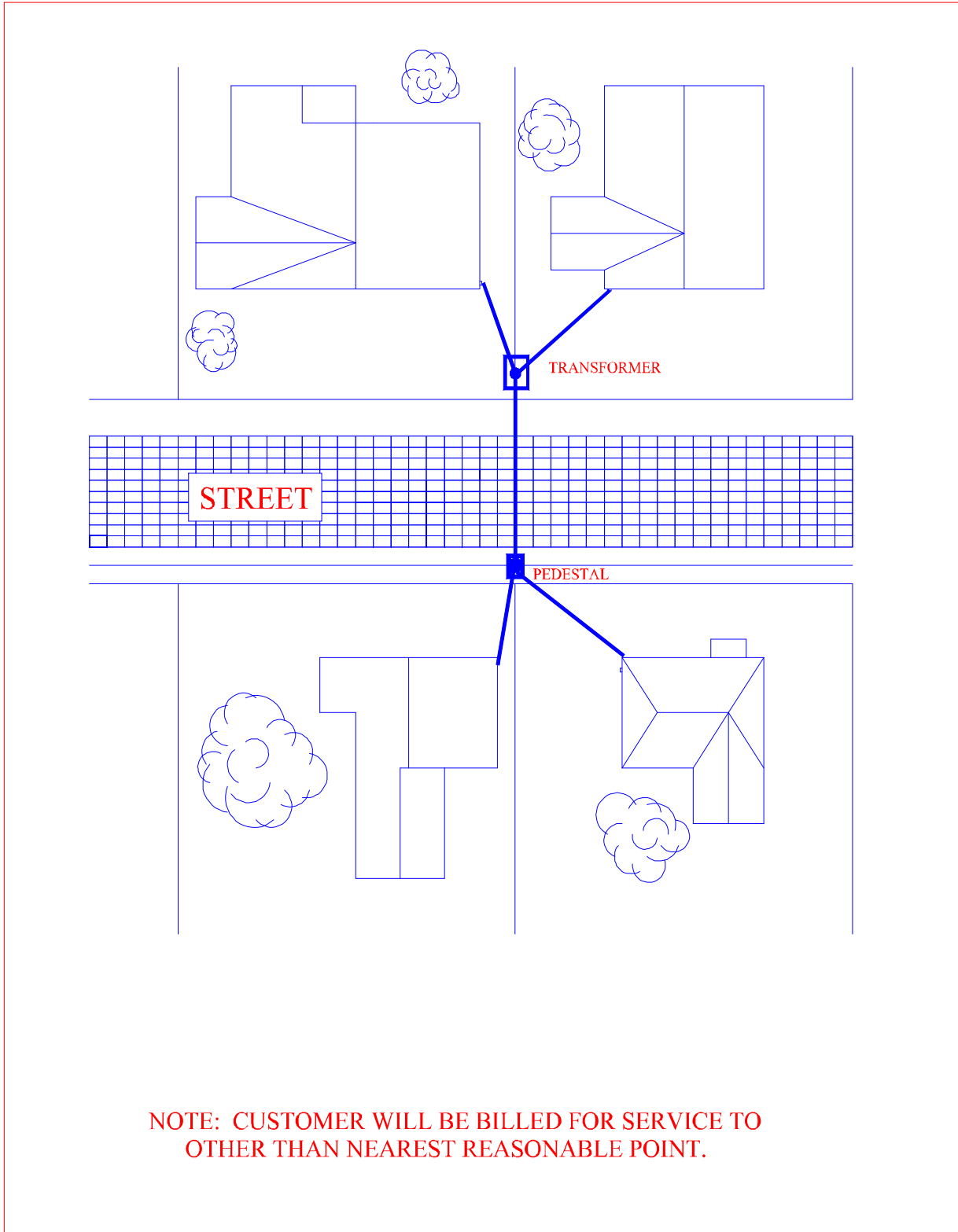

NOTE: CUSTOMER WILL BE BILLED FOR SERVICE TO OTHER THAN NEAREST REASONABLE POINT.

DRAWN BY:	rjl	DATE:	1/4/2002	TYPICAL UNDERGROUND LINE ARRANGEMENT	FILE NAME:	III-8
REVISION:	7/7/06	REV BY:	trh		SCALE:	
ELECTRIC SERVICE STANDARDS				Cleco Power LLC	SH. 1 OF	
				PINEVILLE , LOUISIANA	1 SHEETS	

Fig. III-8 Typical UG Line Arrangement

ELECTRIC SERVICE STANDARDS

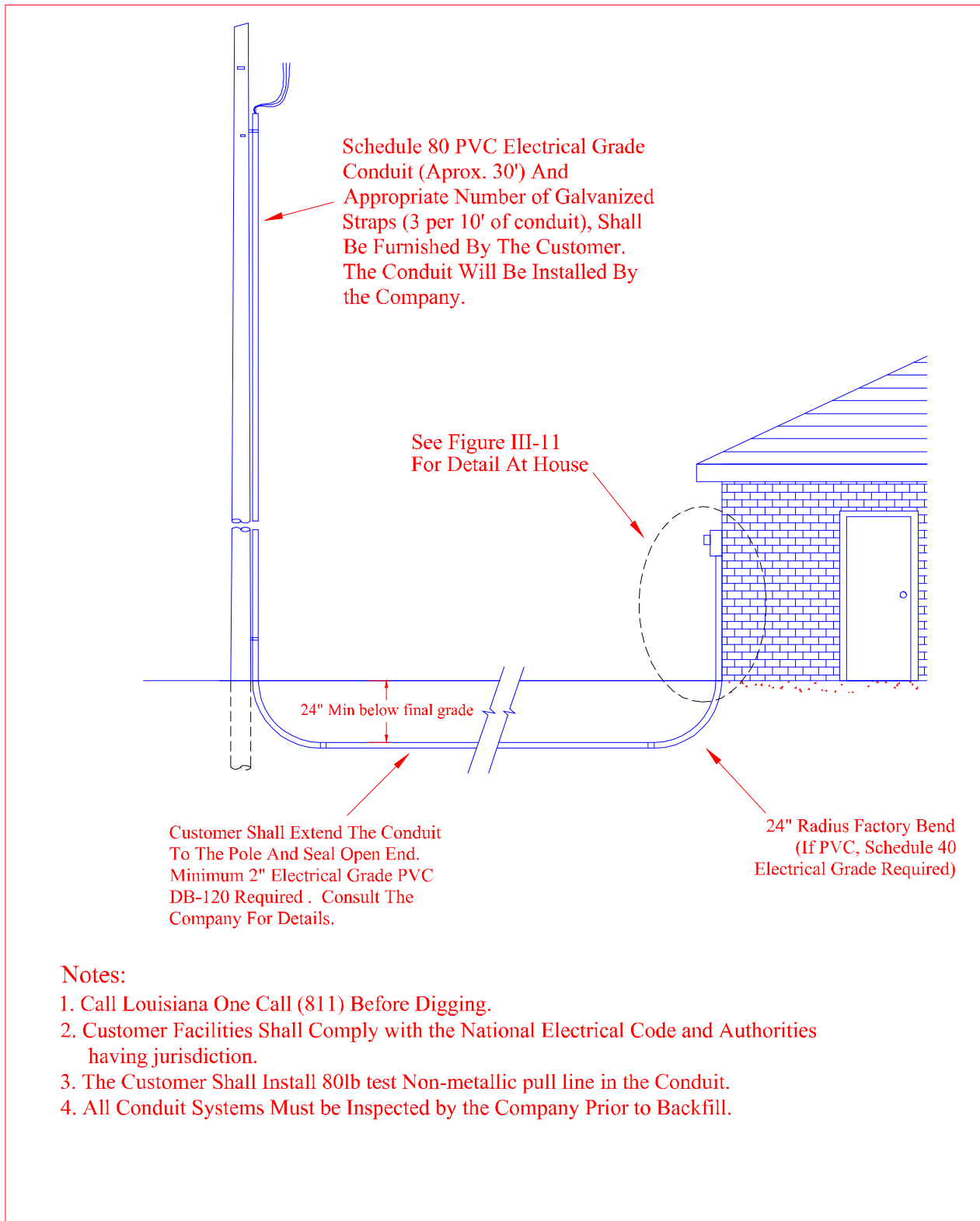

DRAWN BY:	rjl	DATE:	1/4/2002	1Ø Residential Underground Service from Overhead w/Customer Installed Conduit	FILE NAME:
REVISION:	10/15/12	REV BY:	sjc		III-9
ELECTRIC SERVICE STANDARDS				Cleco Power LLC PINEVILLE , LOUISIANA	SCALE:
					SH. 1 OF 1 SHEETS

Fig. III-9 Single Phase Residential Underground Service from Overhead

ELECTRIC SERVICE STANDARDS

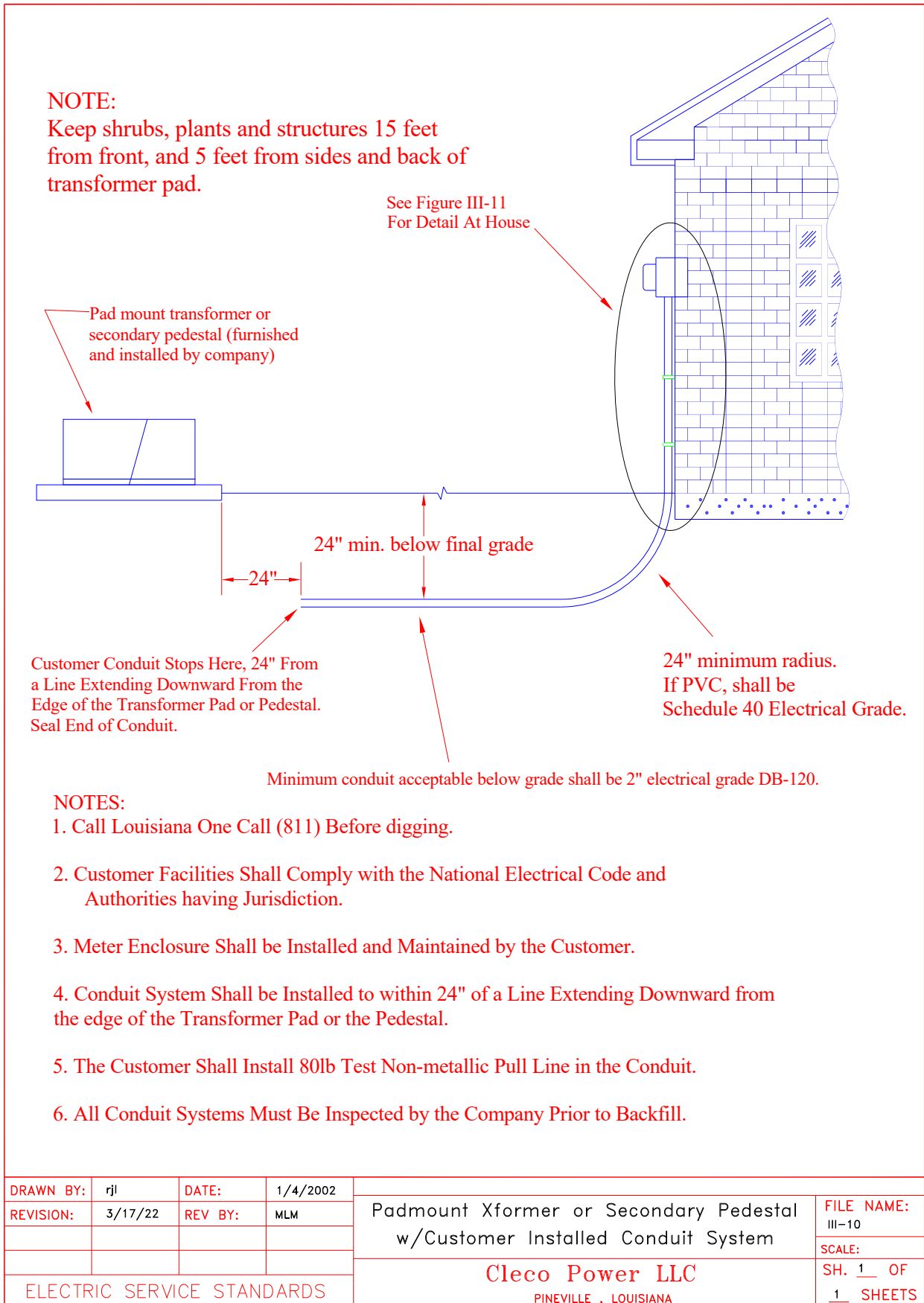

Fig. III-10 Single Phase Residential UG Service from Padmount or Pedestal

ELECTRIC SERVICE STANDARDS

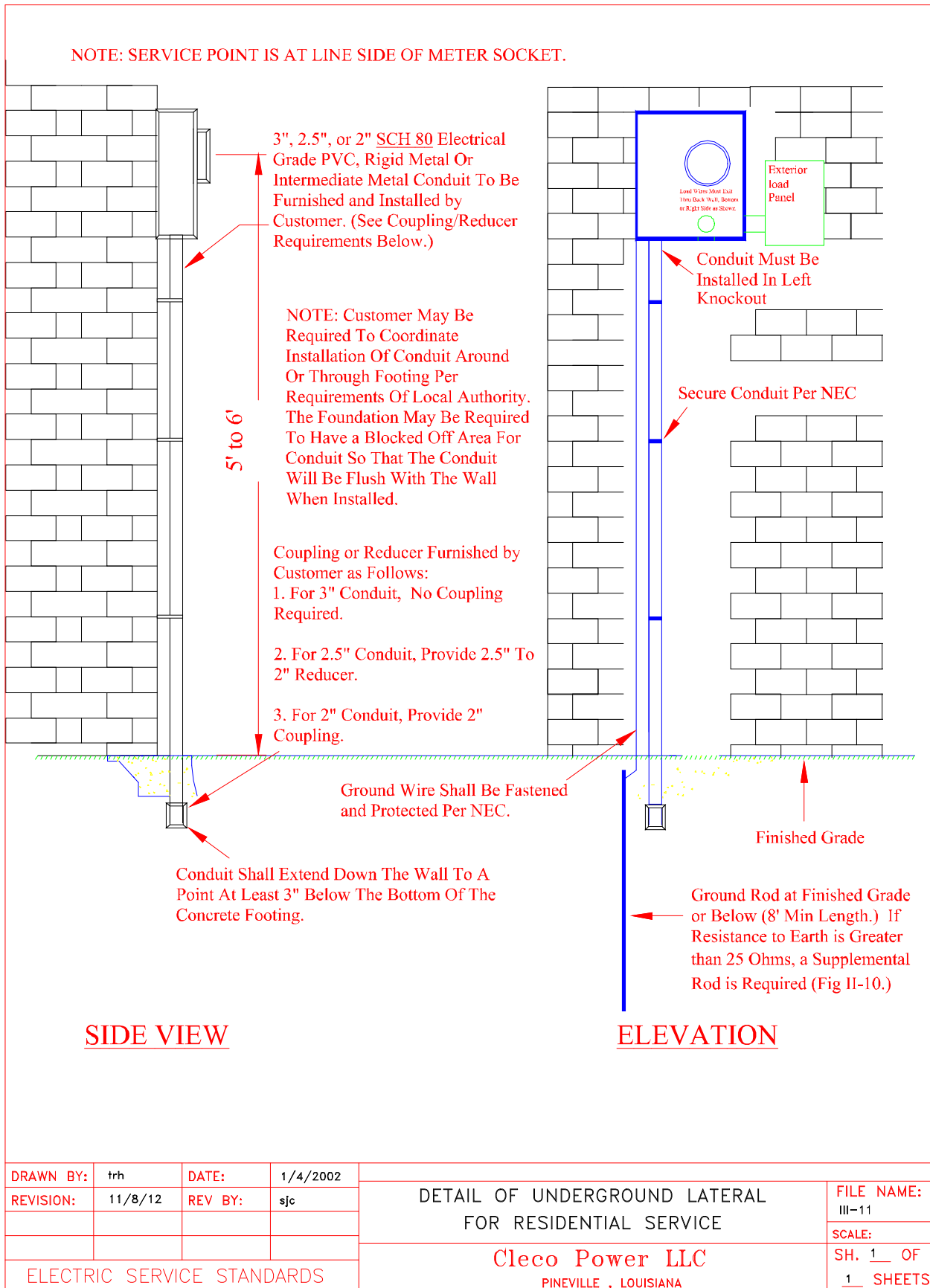

Fig. III-11 Detail of UG Lateral for Residential Service

ELECTRIC SERVICE STANDARDS

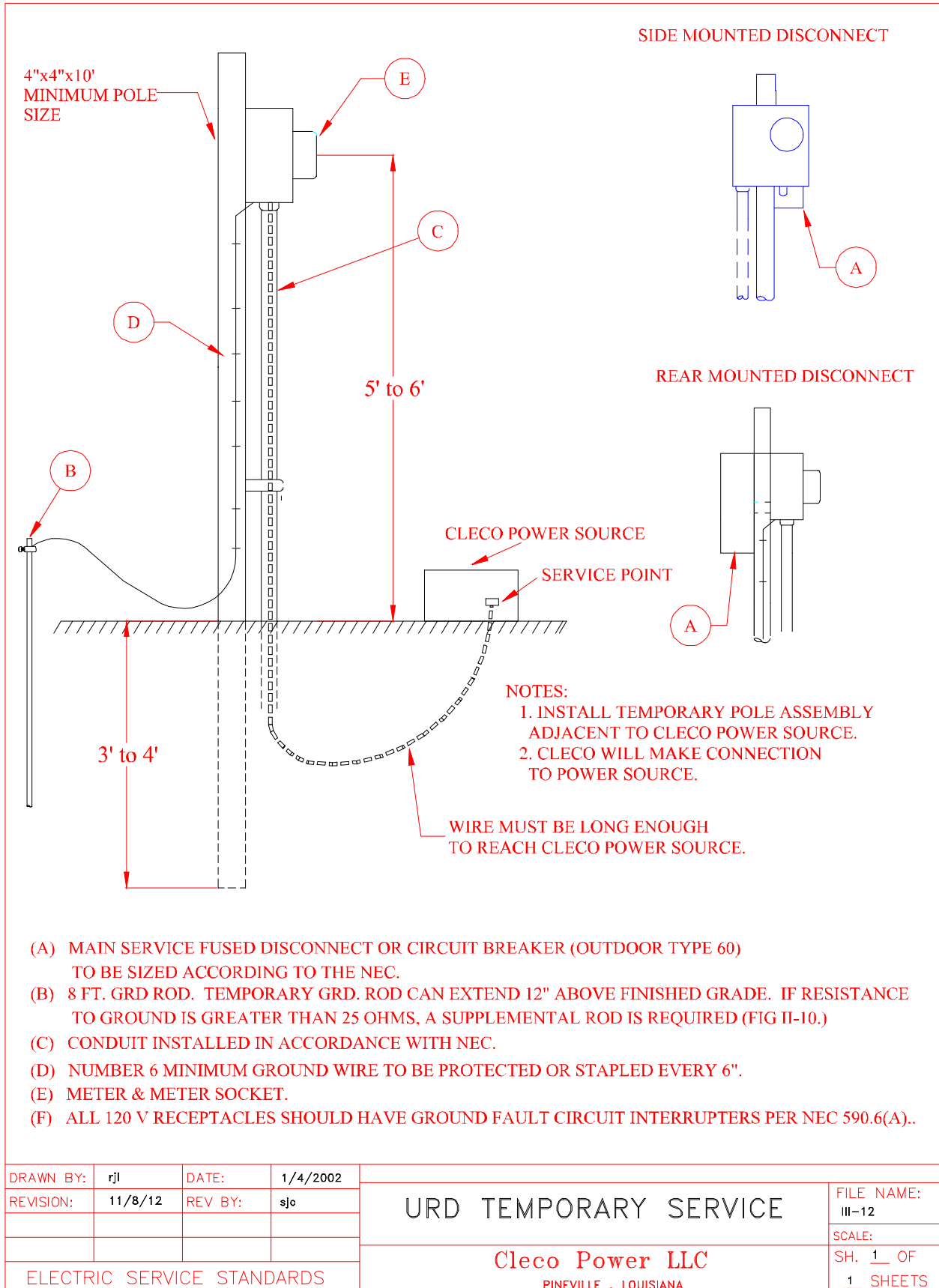

Fig. III-12 URD Temporary Service

ELECTRIC SERVICE STANDARDS

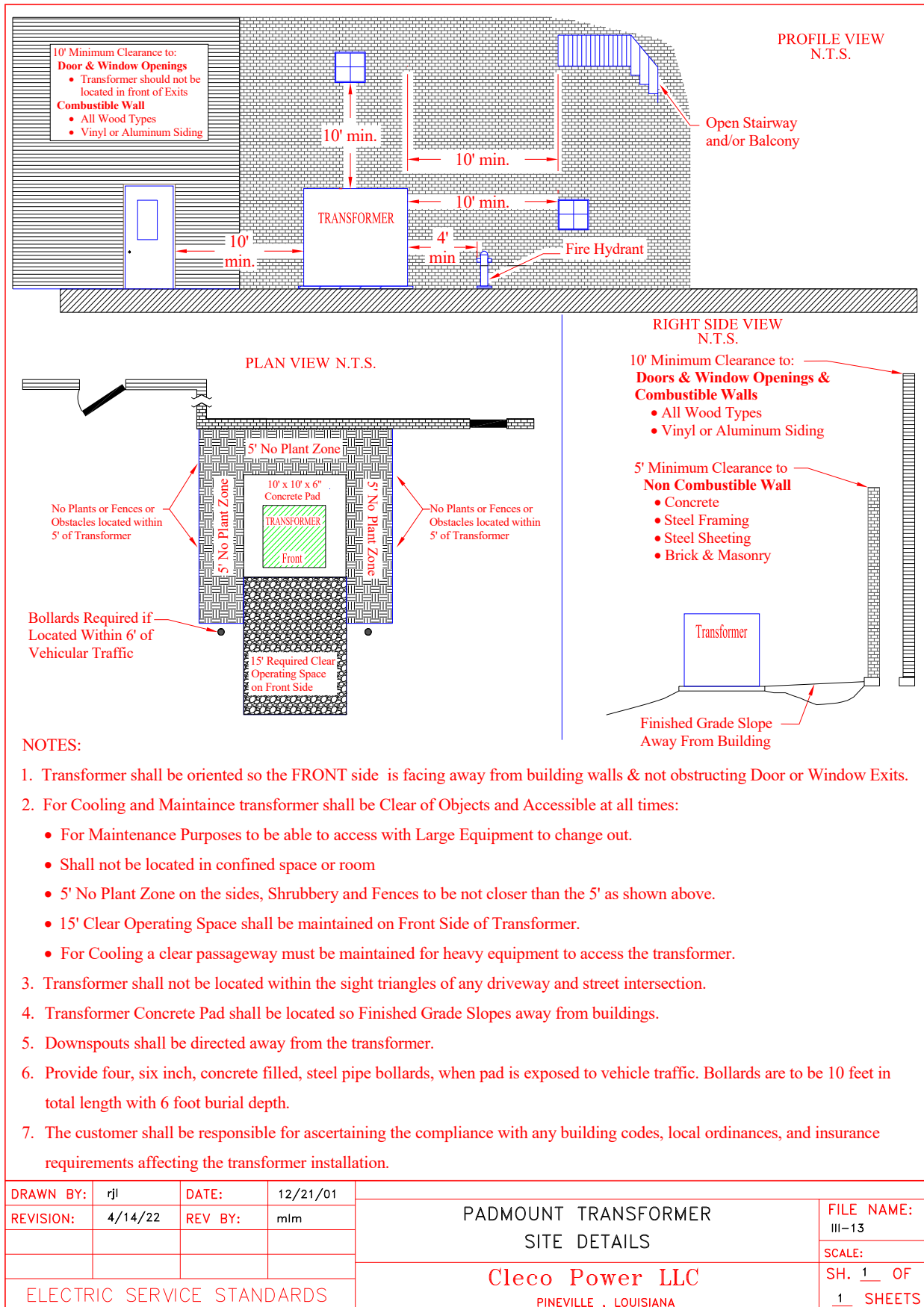
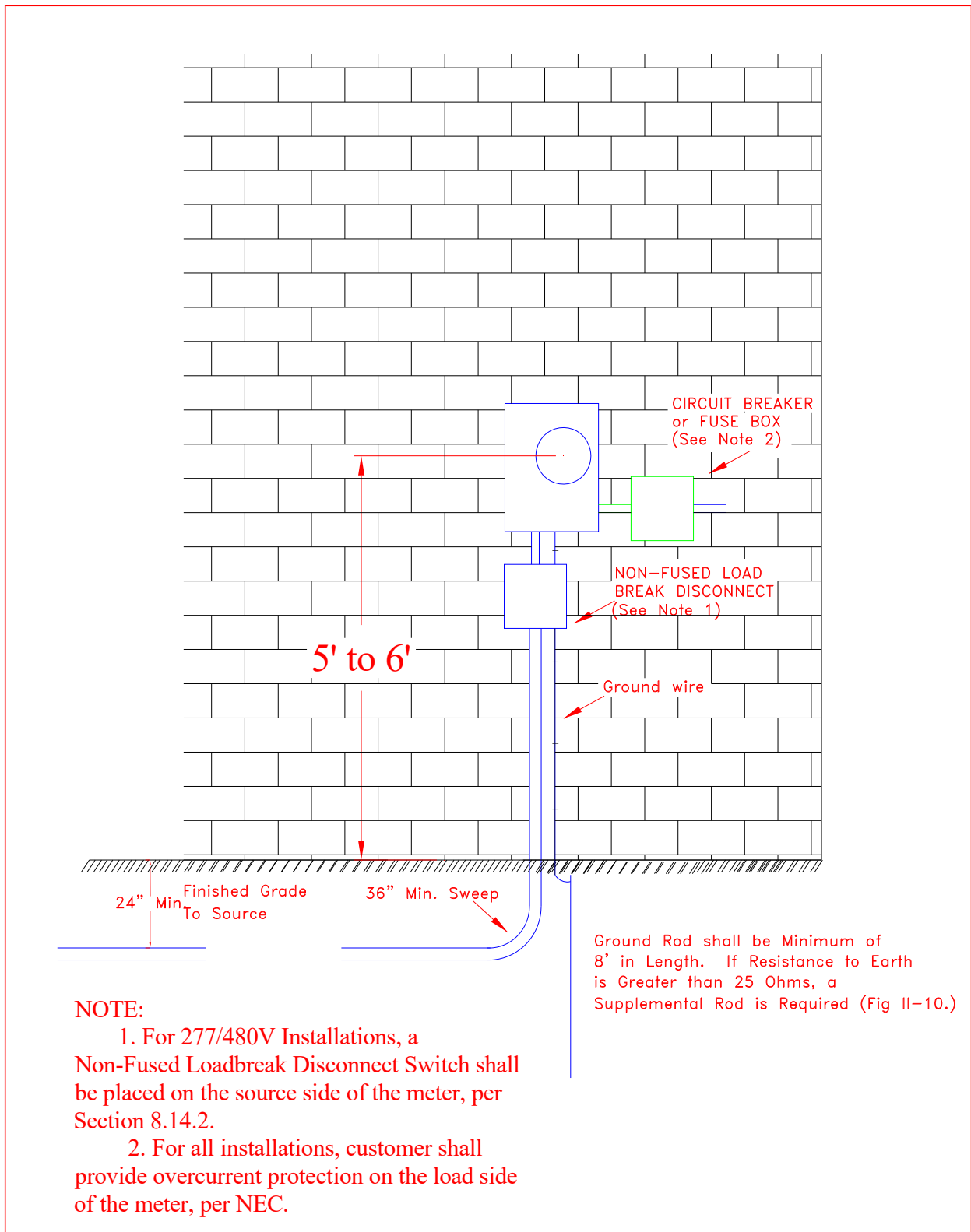

Fig. III-13 Padmount Transformer site Details

ELECTRIC SERVICE STANDARDS



DRAWN BY:	trh	DATE:	10/15/02	277/480 VOLT UNDERGROUND SELF CONTAINED INSTALLATION	FILE NAME:
REVISION:	4/21/2015	REV BY:	DLG		III-14
				Cleco Power LLC PINEVILLE , LOUISIANA	SCALE:
ELECTRIC SERVICE STANDARDS					SH. 1 OF
					1 SHEETS

Fig. III-14 277/480 Volt Underground Self-Contained Installation

APPENDIX IV

REQUIREMENTS FOR SERVICES WITH MAIN
LARGER THAN 400 AMPERES

This Page Left Blank Intentionally

ELECTRIC SERVICE STANDARDS

A4: REQUIREMENTS FOR SERVICES LARGER THAN 400 AMPERES

A4.1 GENERAL

The Company will designate the meter location for services larger than 400 amperes. Requirements of Section 8, Customer's Installation and Service Equipment, shall also apply to this Section except where they conflict, in which case the requirements of this Section shall apply.

A4.2 OVERHEAD SERVICES, 600 AMPERES

The meter location shall be on the building wall at a point nearest the Company's power source. The Company will furnish and install a triplex or quadruplex service drop between the Company's transformer and the Customer's building, provided the distance does not exceed 125 feet. The Company will also furnish the necessary meter enclosure (Trans-socket). The Customer shall install the meter enclosure and furnish and install a grounding conductor from the neutral conductor to the grounding electrode per NEC requirements for this size service. The Customer will also furnish and install a suitably anchored 5/8" eyebolt per Figure II-9. If required by local engineering, for 277/480V services the customer shall provide and install a non-fused load break disconnect switch on the source side of the meter enclosure, per Section 8.14.2 and 8.14.3. See Figures IV-1 and IV-3 for details.

A4.3 OVERHEAD SERVICES, LARGER THAN 600 AMPERES

The Customer shall consult with the Company when planning for services over 600 Amperes in order to resolve any detail conflicts. Failure to notify the Company of the proposed installation may cause a delay in obtaining electric service. The Company shall designate the meter location. Installations requiring building mounted metering for service entrances larger than 600 Amperes, shall be constructed as indicated on Figures IV-5, IV-6, and IV-9. The Company will furnish the appropriate metering enclosure, meter socket, and metering devices. The Customer shall be responsible for installing the metering enclosure and meter socket and the associated conduits between them and the service entrance equipment. The Customer shall furnish and install a properly sized square junction box unless the service entrance conductors can be terminated directly into the terminals of the adjacent Main Disconnect. In either situation, the Customer shall make the connections of the service entrance conductors to the Main Disconnect and the Company shall provide the termination blocks and make the connections to the service drop in the junction box. Conductor routing through the metering enclosure should be such that the longest possible radius is utilized and all conductors pass smoothly through the CT's. If required by local engineering, for 277/480V services the customer shall provide and install a non-fused load break disconnect switch on the source side of the meter enclosure, per Section 8.14.2 and 8.14.3.

Note: The meter enclosure shall not be used as a junction box and the service equipment shall be arranged such that source conductors do not cross load conductors inside any enclosure.

A4.4 UNDERGROUND SERVICES, 600 AMPERES:

A4.4.1 UNDERGROUND SERVICE FROM OVERHEAD OR UNDERGROUND SOURCE: The meter location shall be on the building wall at a point nearest the Company's power source. The Company will furnish and install a triplex or quadruplex service lateral between the Company's power source and the Customer's service entrance. The Company will also furnish the necessary meter enclosure (Transocket). The Customer shall install the meter enclosure and furnish and install a grounding conductor from the neutral conductor to the grounding electrode per NEC requirements for this size service. Refer to Figures IV-2 and IV-4 for details.

A4.4.2 FROM A PADMOUNTED TRANSFORMER

(a) Single Customer Installation:

The metering equipment will be supplied and installed by CLECO on the secondary compartment of the transformer. The Customer must supply and install any conduits and service entrance conductors from the transformer to the service entrance equipment. Conductors shall be of sufficient length and adequately labeled to identify each phase conductor, neutral conductor, and grounding conductor. The Company will make connections to transformer bushings.

Note: With prior approval by Cleco engineering, the Customer may not be required to furnish a non-fused load break disconnect switch ahead of the metering equipment for this application at 277/480V, instead the transformer high voltage switches or fuses may be utilized to de-energize the service lateral.

(b) Multiple Customer Installation:

The metering installation for each large Customer from the single transformer shall be installed on the

ELECTRIC SERVICE STANDARDS

building at a point nearest the transformer. CLECO will furnish the meter enclosure and the CT cabinet. The Customer(s) will furnish and install a properly sized junction box per Figure V-3 and a non-fused load break disconnect switch to be placed on the source(Company) side of the meter.

Note: The CT cabinet shall not be used as a junction box and the service equipment shall be arranged such that source conductors do not cross load conductors inside any enclosure.

A4.5 UNDERGROUND SERVICES LARGER THAN 600 AMPERES

A4.5.1 FROM OVERHEAD SOURCE

The Customer shall consult with the Company when planning for services over 600 Amperes in order to resolve any detail conflicts. Failure to notify the Company of the proposed installation may cause a delay in obtaining electric service. The Company shall designate the meter location. Installations requiring building mounted metering for service entrances larger than 600 Amperes, shall be constructed as indicated in Figures IV-7, IV-8, and IV-10. The Company will furnish the appropriate metering enclosure, meter socket, and metering devices. The Customer shall install the metering enclosure and meter socket and the associated conduits between them and the service entrance equipment. The Customer shall also furnish and install a properly sized square junction box unless the service lateral conductors can be terminated directly into the terminals of the adjacent Main Disconnect (Note: The Company utilizes aluminum service lateral conductors with a maximum size of 350 MCM). In either situation, the Customer shall make the connections of the service entrance / service lateral conductors to the Main Disconnect and the Company shall provide the termination blocks and make the connections to the service lateral in the junction box. Conductor routing through the metering enclosure should be such that the longest possible radius is utilized and all conductors pass smoothly through the CT's. The Customer shall furnish and install a grounding conductor from the meter socket to the grounding electrode per NEC requirements for this size service. If required by local engineering, for 277/480V services the customer shall provide and install a non-fused load break disconnect switch on the source side of the meter enclosure, per Section 8.14.2 and 8.14.3. Refer to Figures IV-7, IV-8, and IV-10 for details.

Note: The meter enclosure shall not be used as a junction box and the service equipment shall be arranged such that source conductors do not cross load conductors inside any enclosure.

A4.5.2 FROM A PADMOUNTED TRANSFORMER

- (a) **Single Meter Installation:** The Company shall furnish and install the metering equipment on the secondary compartment of the transformer provided the service entrance is not less than 800A. (Service entrances less than 800A are self-contained and will not be mounted on the transformer.) The Customer shall furnish and install all service conduits and service lateral conductors from the transformer to the service entrance equipment. Service lateral conductors shall be of sufficient length and adequately labeled / color coded to identify each phase conductor, neutral conductor, and grounding conductor. Service Lateral conductors are limited to a maximum size of 750 kcmil. The Company will furnish and install the connectors on the transformer secondary bushings to the Customer's service lateral conductors. Table 8.1 shows the maximum number of parallel service laterals which are allowed to be physically connected to the transformer. Any questions about these limitations should be discussed with the Company's engineering representative prior to installation. **Note:** Transformer secondary bushings shall not be used in any way for pulling service lateral conductors.

Note: With prior approval by Cleco engineering, the Customer may not be required to furnish a non-fused load break disconnect switch ahead of the metering equipment for this application at 277/480V, instead the transformer high voltage switches or fuses may be utilized to de-energize the service lateral.

- (b) **Multiple Meter Installation:** Up to two sets of instrument metering may be mounted on the transformer secondary compartment with Company concurrence. Otherwise, the meter location shall be on the building wall at a point nearest the Company's transformer and all meters shall be grouped as closely as possible. Refer to Figures V-1 and V-2 for details. The Company will furnish and install a separate triplex or quadruplex service lateral between the Company's transformer and the Customer's service entrances. The Company will also furnish the necessary meter enclosures, meter sockets, and metering devices for each service of 600 Amperes or larger. The Customer shall install the metering enclosures and meter sockets and the associated conduits between them and the service entrance equipment. The Customer shall furnish and install properly sized square junction boxes unless each set of service lateral conductors can be terminated directly into the terminals of the adjacent Main Disconnects. (Note: The Company utilizes aluminum service lateral conductors).

ELECTRIC SERVICE STANDARDS

In either situation, the Customer shall make the connections of the service entrance / service lateral conductors to the Main Disconnect and the Company shall provide the termination blocks and make the connections to the service lateral in the junction box. Conductor routing through the metering enclosure should be such that the longest possible radius is utilized and all conductors pass smoothly through the Current Transformers (CT). The Customer shall also furnish and install a grounding conductor from the meter socket to the grounding electrode per NEC requirements for this size service. Refer to Figures IV-7, IV-8, and IV-10 for details.

Note: For all applications where multiple occupancies exist within a single premise, the Customer is urged to utilize factory designed meter centers. The factory designed meter centers, including commercial metering switchboards, shall utilize ringless, cold sequence design.

- (c) **Multiple Meter Installation 277/480V, 3 Phase, 4 Wire:** The meter locations shall be on the building wall at a point nearest the Company's transformer and all meters shall be grouped as closely as possible. Refer to Figures V-1 and V-2 for additional details. The Company will furnish and install a separate quadruplex service lateral between the Company's transformer and the Customer's service entrances. The Company will also furnish the necessary meter enclosures, meter sockets, and metering devices for each service of 600A or larger. The Customer shall install the metering enclosures and meter sockets and the associated conduits between the Company and the service entrance equipment. Each Customer shall furnish and install a non-fused load break disconnect switch, sized per NEC requirements, on the source (Company) side of each metering enclosure. This switch will be locked by Cleco and shall only be operated by Cleco personnel. A separate, properly sized overcurrent protective device shall be installed on the load side of the metering enclosure per NEC requirements and/or local codes. The Customer shall furnish and install properly sized square junction boxes unless each set of service lateral conductors can be terminated directly into the terminals of the adjacent disconnects. (Note: The Company utilizes aluminum service lateral conductors.) In either situation, the Customer shall make the connections of the service entrance/service lateral conductors in the disconnect and the Company shall provide the termination blocks and make the connections to the service lateral in the junction box and/or transformer. Conductor routing through the metering enclosure should be such that the longest possible radius is utilized and all conductors pass smoothly through the CT's. The Customer shall also furnish and install a grounding conductor from the meter socket to the grounding electrode per NEC requirements for this service type. Refer to Figures IV-7, IV-8, and IV-10 for details.
- Note:** Installations where the NEC requires aggregating the services to limit the number of disconnects on a single premise, an individual non-fused load break disconnect ahead of each meter will still be required. For all applications where multiple occupancies exist within a single premise, the Customer is urged to utilize factory designed meter centers. The factory designed meter centers (including commercial metering switchboards) shall utilize ringless, cold sequence design for applications through 600V.

ELECTRIC SERVICE STANDARDS

This Page Left Blank Intentionally

TRANSOCKET OVERHEAD SERVICE ENTRANCE

1-phase, 3-Wire, 120/240 Volts, 600 Amps

2-Phase, 3-Wire, 120/208 Volts, 600 Amps

3-Phase, 4-Wire, 120/208 Volts, 600 Amps

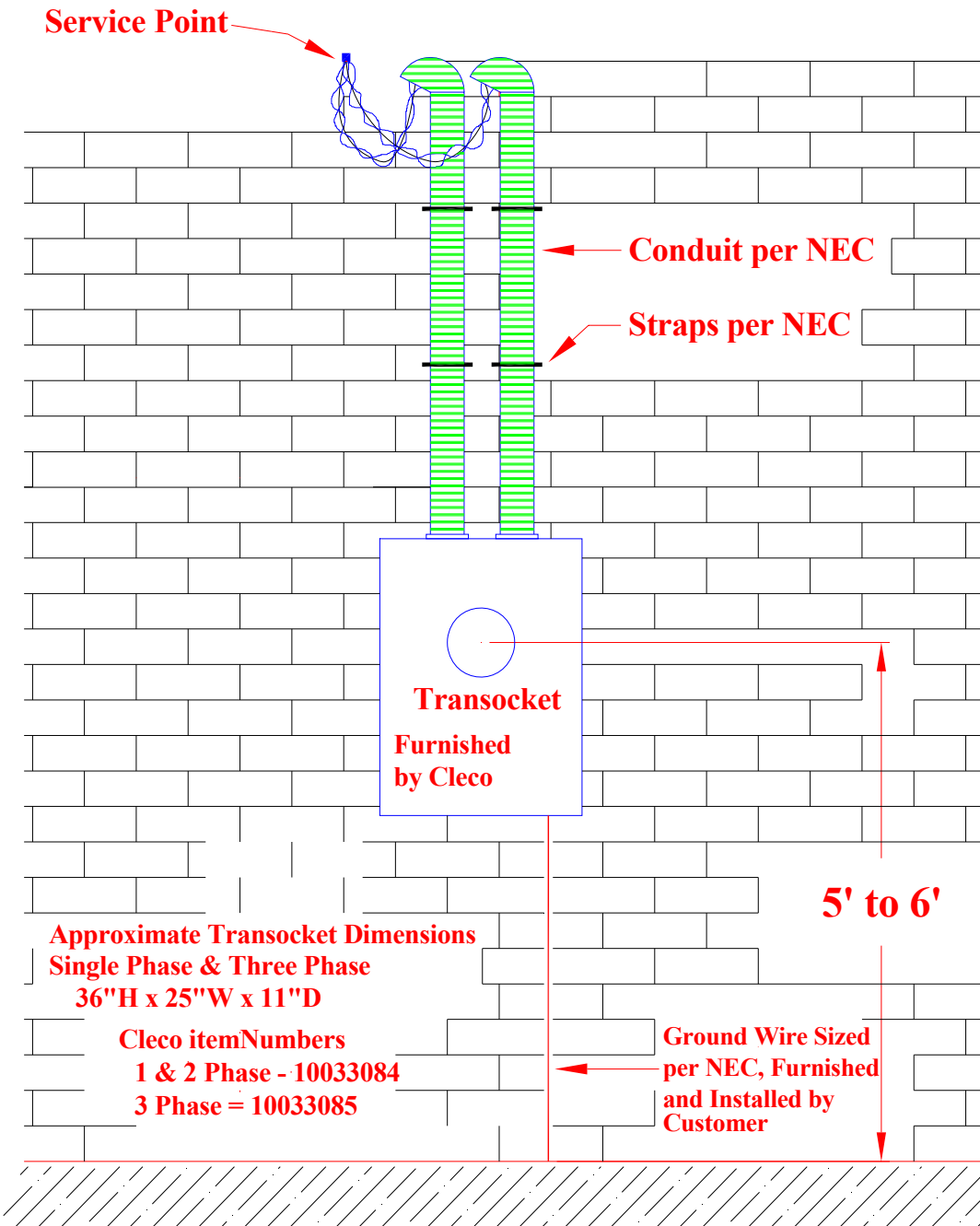

Approximate Transocket Dimensions

Single Phase & Three Phase

36"H x 25"W x 11"D

Cleco itemNumbers

1 & 2 Phase - 10033084

3 Phase = 10033085

trh	DATE:	12/22/04	TRANSOCKET OH SERVICE ENTRANCE 1-PHASE 2-PHASE & 3-PHASE	FILE NAME:	IV-1
11/18/19	REV BY:	MLM		SCALE:	
ELECTRIC SERVICE STANDARDS			Cleco Corporation PINEVILLE, LOUISIANA	SH. 1 OF	1 SHEETS

Fig. IV-1 Transocket-OH Service 120/240, 120/208 Volts, 600 Amps

TRANSOCKET UNDERGROUND SERVICE ENTRANCE

**1-Phase, 3-Wire, 120/240 Volts, 600 Amps
 2-Phase, 3-Wire, 120/208 Volts, 600 Amps
 3-Phase, 4-Wire, 120/208 Volts, 600 Amps**

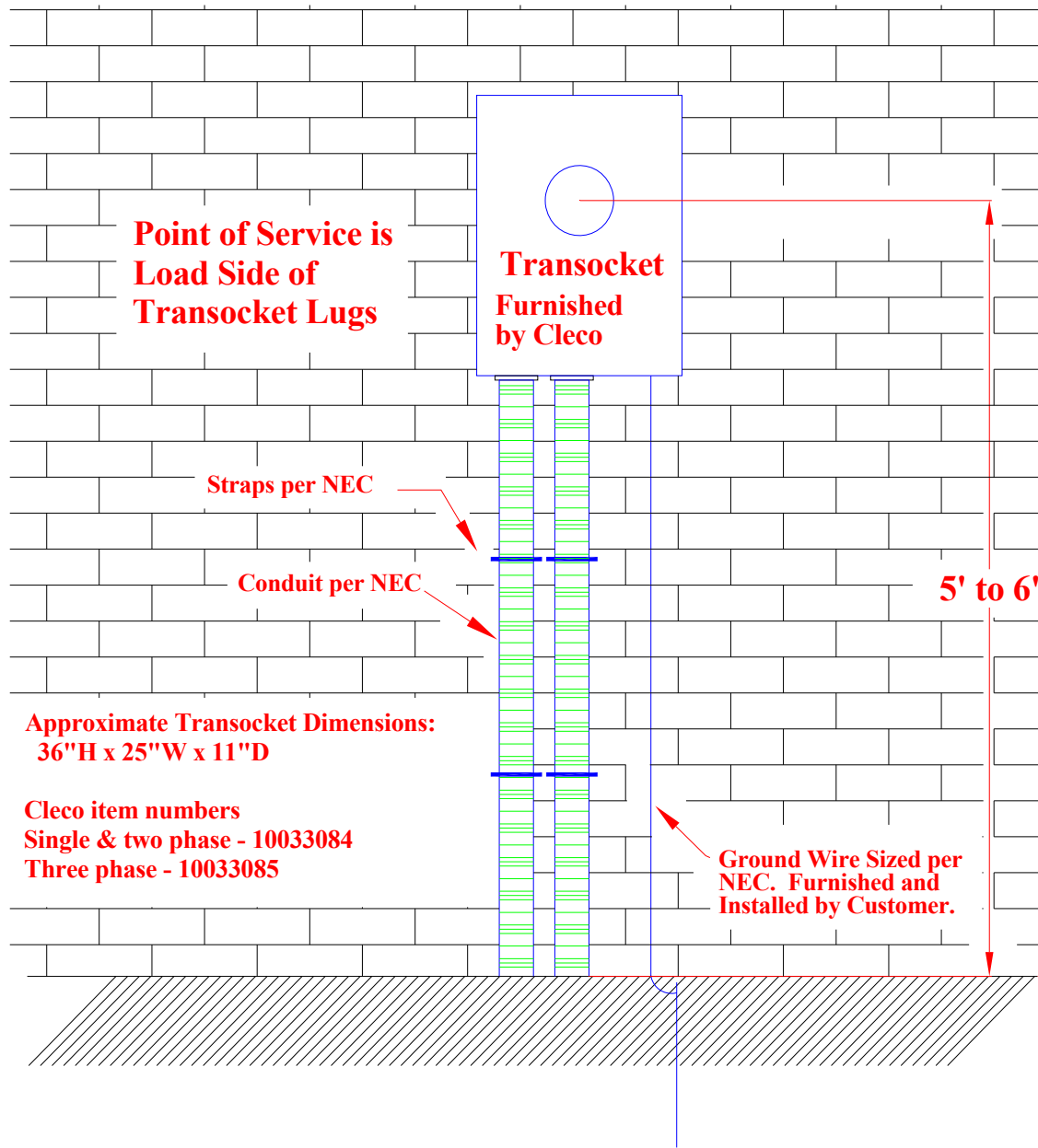

DRAWN BY:	trh	DATE:	12/22/04	TRANSOCKET UG SERVICE ENTRANCE 1 PHASE, 2-PHASE & 3 PHASE	FILE NAME:	IV-2
REVISION:	11/18/19	REV BY:	MLM		SCALE:	SH. ___ OF ___ SHEETS
ELECTRIC SERVICE STANDARDS				Cleco Corporation PINEVILLE, LOUISIANA		

Fig. IV-2 Transocket-UG Service 120/240, 120/208 Volts, 600 Amps

TRANSOCKET OVERHEAD SERVICE ENTRANCE

3-Phase, 4-Wire, 277/480 Volts, 600 Amps

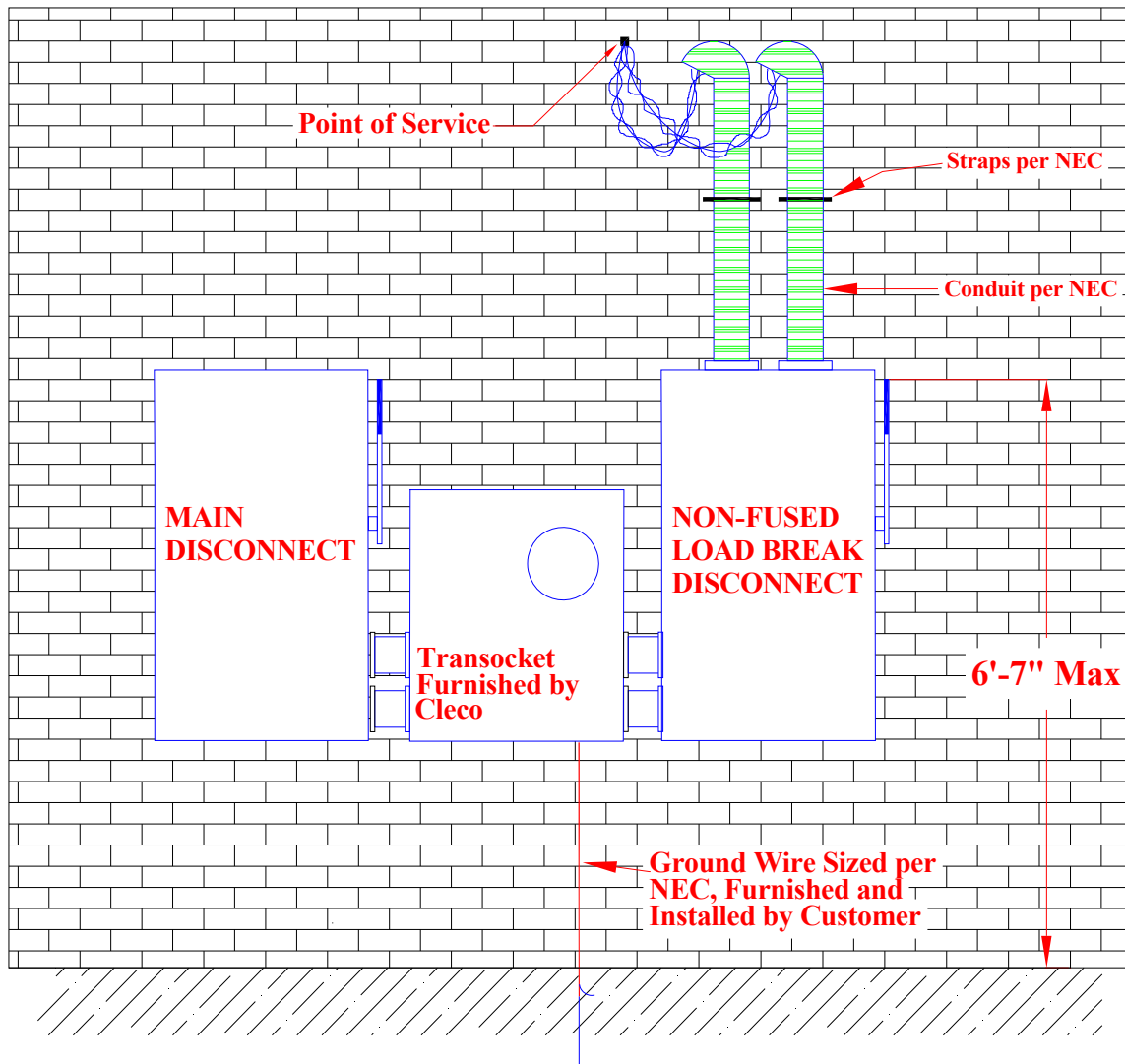

For 277/480V installations a Non-Fused Load Break Disconnect Switch shall be installed on the Source Side of the Meter Enclosure, per Section 8.14.2.

For all installations, overcurrent protection shall be provided on the load side per NEC.

**Approximate Transocket Dimensions:
36"H x 25"W x 11"D**

Cleco item # 10033085 - 3PH 600A Transocket.

DRAWN BY:	trh	DATE:	3/14/05	TRANSOCKET OVERHEAD SERVICE ENTRANCE 3 PHASE, 4 WIRE, 277/480 VOLTS	FILE NAME:	IV-3
REVISION:	11/18/19	REV BY:	MLM		SCALE:	SH. ___ OF ___ SHEETS
ELECTRIC SERVICE STANDARDS				Cleco Corporation PINEVILLE, LOUISIANA		

Fig. IV-3 Transocket OH Service 277/480 Volts, 600 Amps

Transocket UG Service Entrance 3-Phase, 4-Wire, 277/480 Volts, 600 Amps

For 277/480V installations a Non-Fused Load Break Disconnect Switch shall be installed on the Source Side of the Meter, per Section 8.14.2.

For all installations, overcurrent protection shall be provided on the load side of the meter, per NEC.

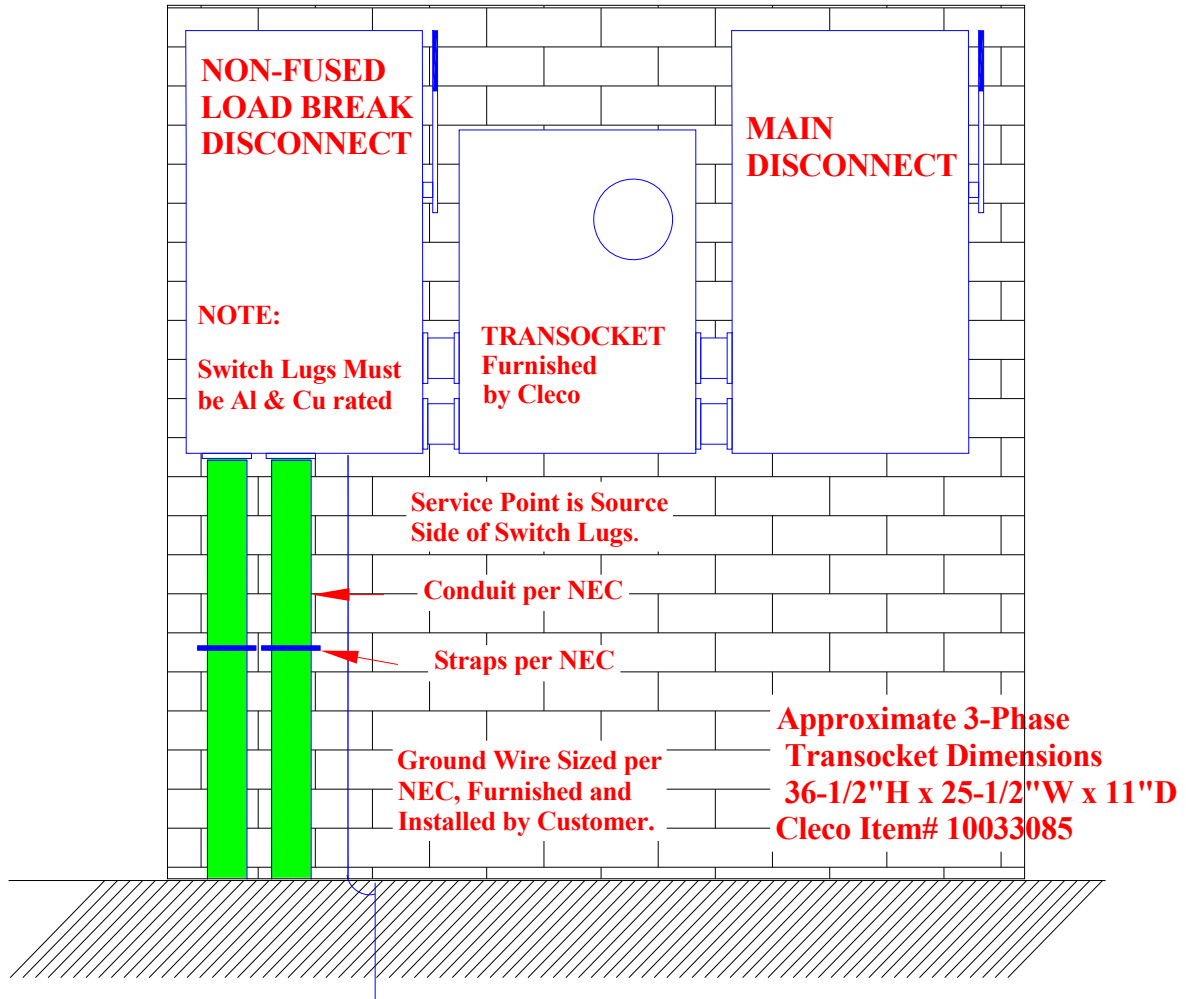

DRAWN BY:	trh	DATE:	12/21/04	TRANSOCKET UG SERVICE ENTRANCE 3-PHASE, 4-WIRE 277/480 VOLTS	FILE NAME:
REVISION:	11/18/19	REV BY:	MLM		IV-4
				Cleco Corporation PINEVILLE, LOUISIANA	SCALE:
ELECTRIC SERVICE STANDARDS					SH. ___ OF ___ SHEETS

Fig. IV-4 Transocket UG Service 277/480 Volts, 600 Amps

CT OVERHEAD SERVICE ENTRANCE

3-PHASE, 4-WIRE 120/208 VOLTS, LARGER THAN 600 AMPS
WITH INTERIOR DISCONNECT

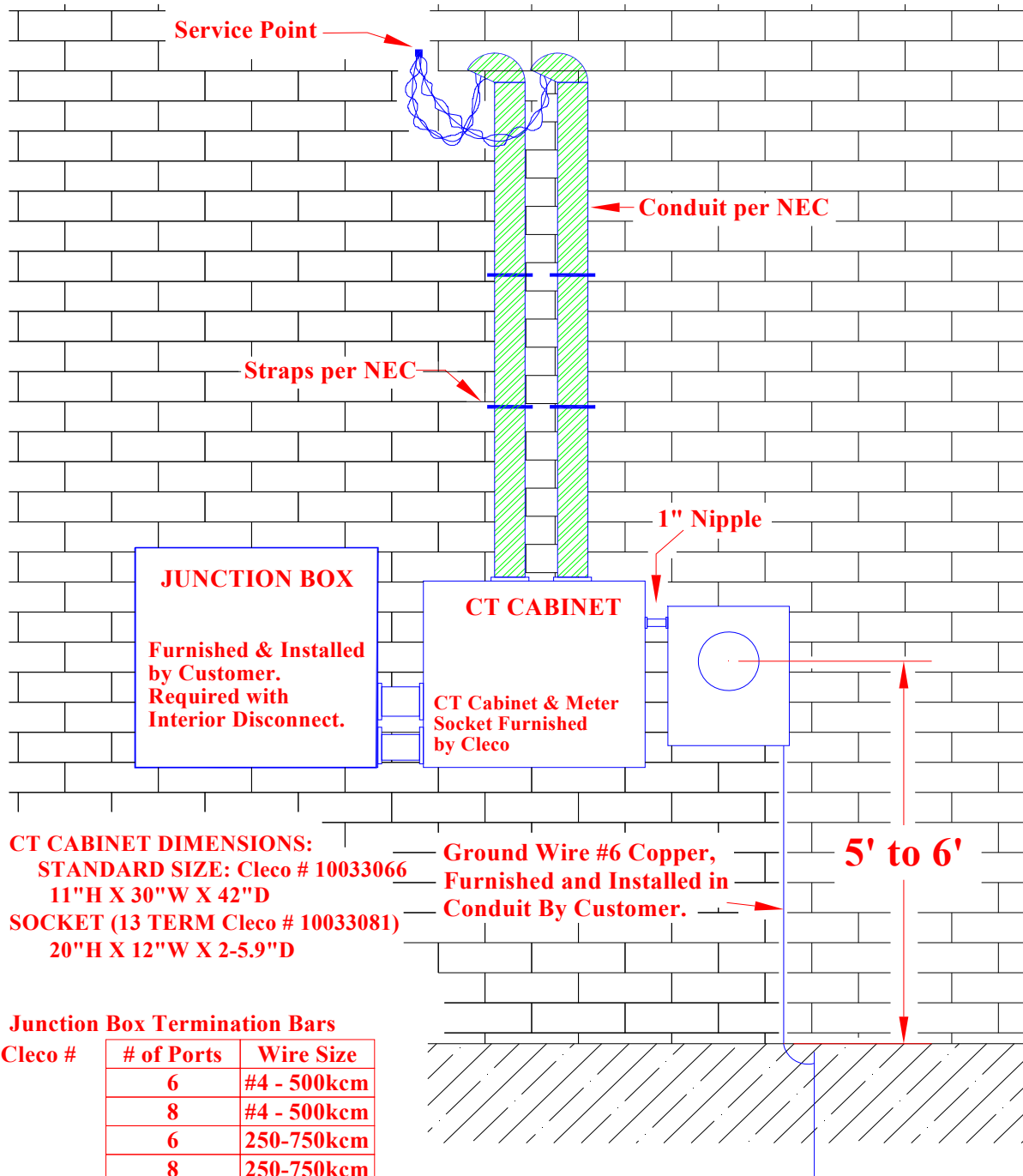

CT CABINET DIMENSIONS:
STANDARD SIZE: Cleco # 10033066
11"H X 30"W X 42"D
SOCKET (13 TERM Cleco # 10033081)
20"H X 12"W X 2-5.9"D

Junction Box Termination Bars

Cleco #	# of Ports	Wire Size
	6	#4 - 500kcm
	8	#4 - 500kcm
	6	250-750kcm
	8	250-750kcm

DRAWN BY:	trh	DATE:	12/21/04
REVISION:	11/18/19	REV BY:	MLM

CT OH SERVICE – W/INTERIOR DISCONNECT
3-PHASE, 4 WIRE 120/208 VOLT

Cleco Corporation
PINEVILLE, LOUISIANA

FILE NAME:
IV-5

SCALE:

SH. ___ OF
___ SHEETS

ELECTRIC SERVICE STANDARDS

Fig. IV-5 CT OH Service – Interior Disconnect 120/208 Volts, Larger than 600 Amps

CT OVERHEAD SERVICE ENTRANCE
3-PHASE, 4-WIRE 120/208 VOLTS, LARGER THAN 600 AMPS
EXTERIOR DISCONNECT

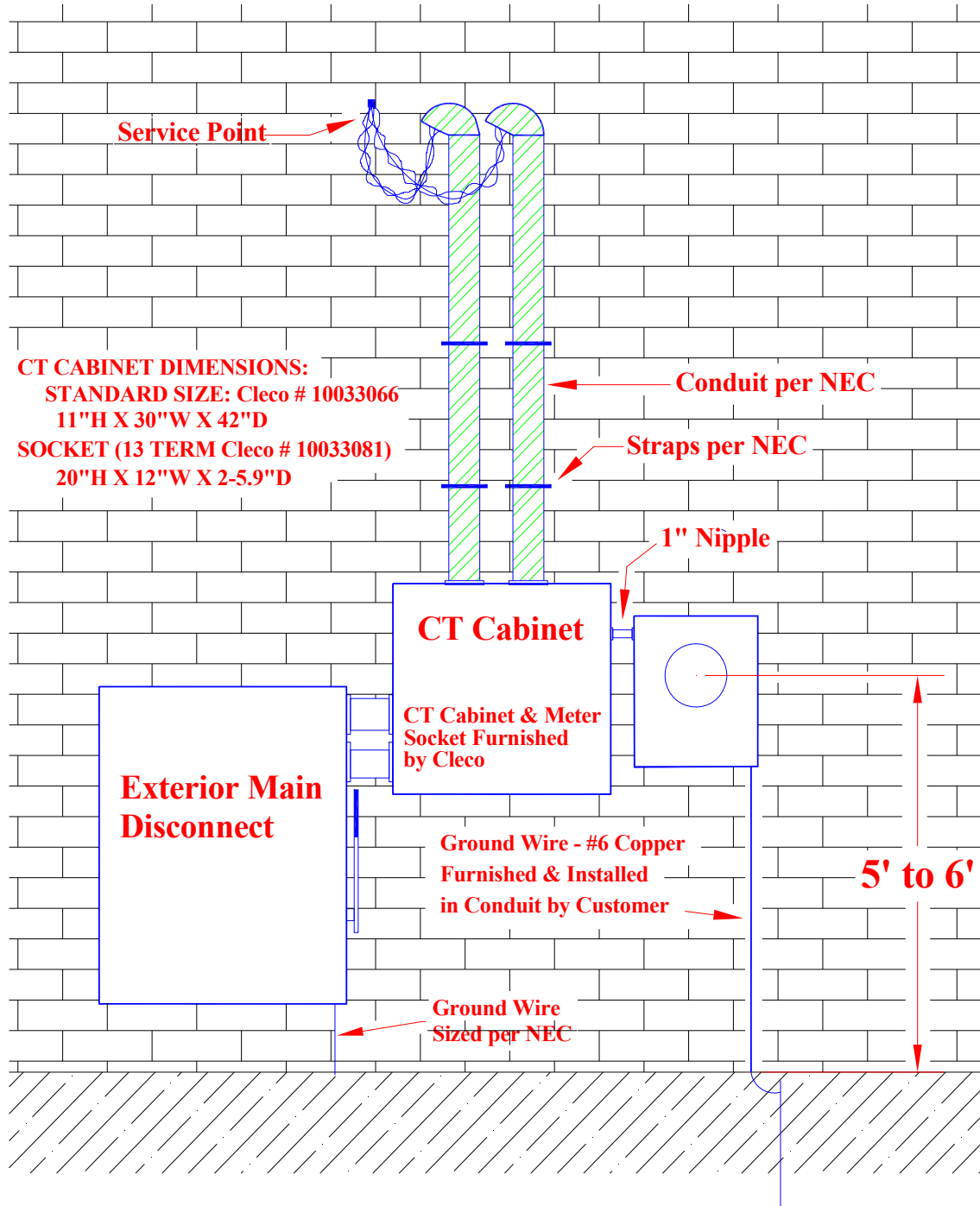

DRAWN BY:	trh	DATE:	11/9/12	CT OH SERVICE – W/EXTERIOR DISCONNECT 3-PHASE, 4 WIRE 120/208 VOLT	FILE NAME:	IV-6
REVISION:	11/18/19	REV BY:	MLM		SCALE:	SH. ___ OF ___ SHEETS
ELECTRIC SERVICE STANDARDS				Cleco Corporation PINEVILLE, LOUISIANA		

Fig. IV-6 T OH Service – Exterior Disconnect 120/208 Volts, Larger than 600 Amps

CT UNDERGROUND SERVICE

3-PHASE 4-WIRE 120/208 VOLTS, LARGER THAN 600 AMPS INTERIOR DISCONNECT

CT Cabinet Dimensions:

Standard Size: (Cleco# 10033066)

11"H x 30"W x 42"D

Socket (13 Terminal Cleco# 10033081)

20"H x 12"W x 5-3/4"D

Junction Box Termination Bars

Cleco #	# of Ports	Wire Size
10032682	6	#4 - 500kcm
10032683	8	#4 - 500kcm
10032684	6	250-750kcm
10032685	8	250-750kcm

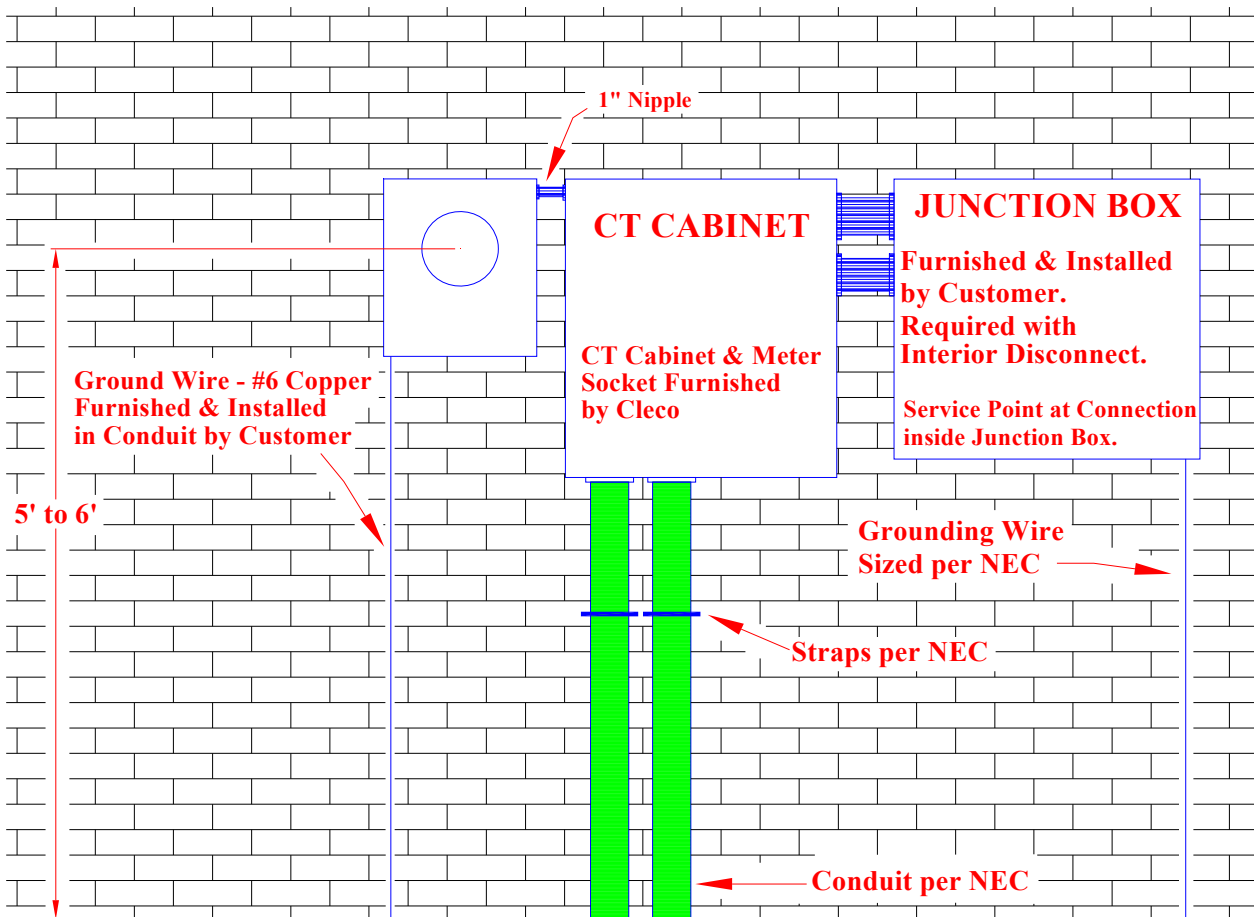

DRAWN BY:	trh	DATE:	11/9/12	CT UG SERVICE W/INTERIOR DISCONNECT 3-PHASE, 4-WIRE 120/208 VOLT	FILE NAME:	IV-7
REVISION:	11/18/19	REV BY:	MLM		SCALE:	
ELECTRIC SERVICE STANDARDS				Cleco Corporation	SH. ___ OF	___ SHEETS
				PINEVILLE, LOUISIANA		

Fig. IV-7 CT UG Service – Interior Disconnect 120/208V, Larger than 600 Amps

CT UNDERGROUND SERVICE

3-PHASE 4-WIRE 120/208 VOLTS, LARGER THAN 600 AMPS EXTERIOR DISCONNECT

CT CABINET DIMENSIONS:

STANDARD SIZE: Cleco # 10033066
11"H X 30"W X 42"D

SOCKET (13 TERMINAL Cleco # 10033081)
20"H X 12"W X 2-5.9"D

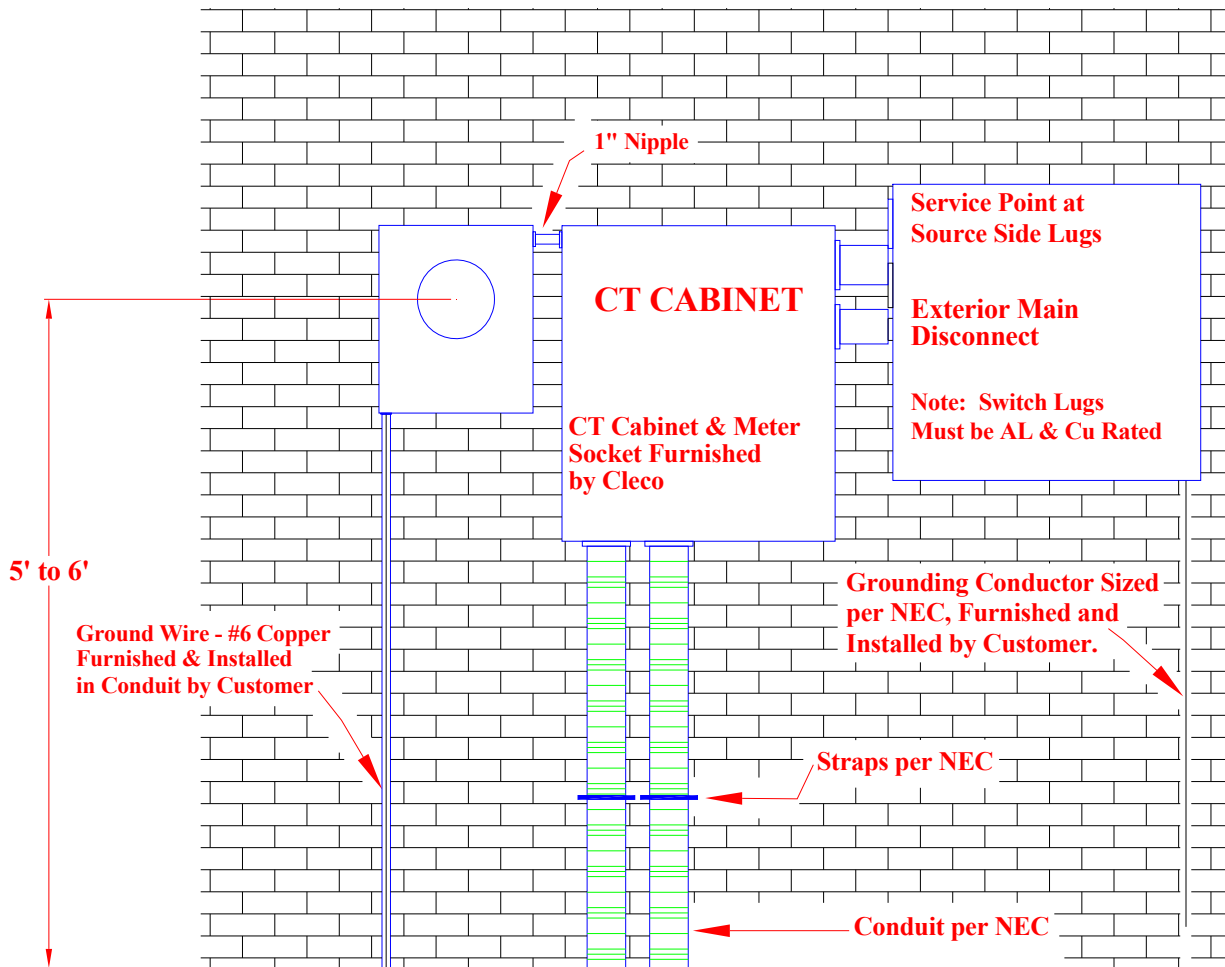

DRAWN BY:	trh	DATE:	11/9/12	CT UG SERVICE W/EXTERIOR DISCONNECT 120/208 VOLT, 3-PHASE, 4-WIRE	FILE NAME:	IV-8
REVISION:	11/18/19	REV BY:	MLM		SCALE:	
ELECTRIC SERVICE STANDARDS				Cleco Corporation PINEVILLE, LOUISIANA	SH. <u> </u> OF	<u> </u> SHEETS

Fig. IV-8 CT UG Service – Exterior Disconnect 120/208V, Larger than 600 Amps

CT OVERHEAD SERVICE ENTRANCE

3-PHASE, 4-WIRE 277/480 VOLTS, LARGER THAN 600 AMPS

CT/PT CABINET DIMENSIONS:

STANDARD SIZE: Cleco # 10033066

11"H X 30"W X 42"D

20"H X 12"W X 2-5.9"D

For 277/480V installations, a Non-Fused Load Break Disconnect Switch shall be installed on the Source Side of the meter, per Section 8.14.2.

For all installations, overcurrent protection shall be provided on the Load Side of the meter, per NEC.

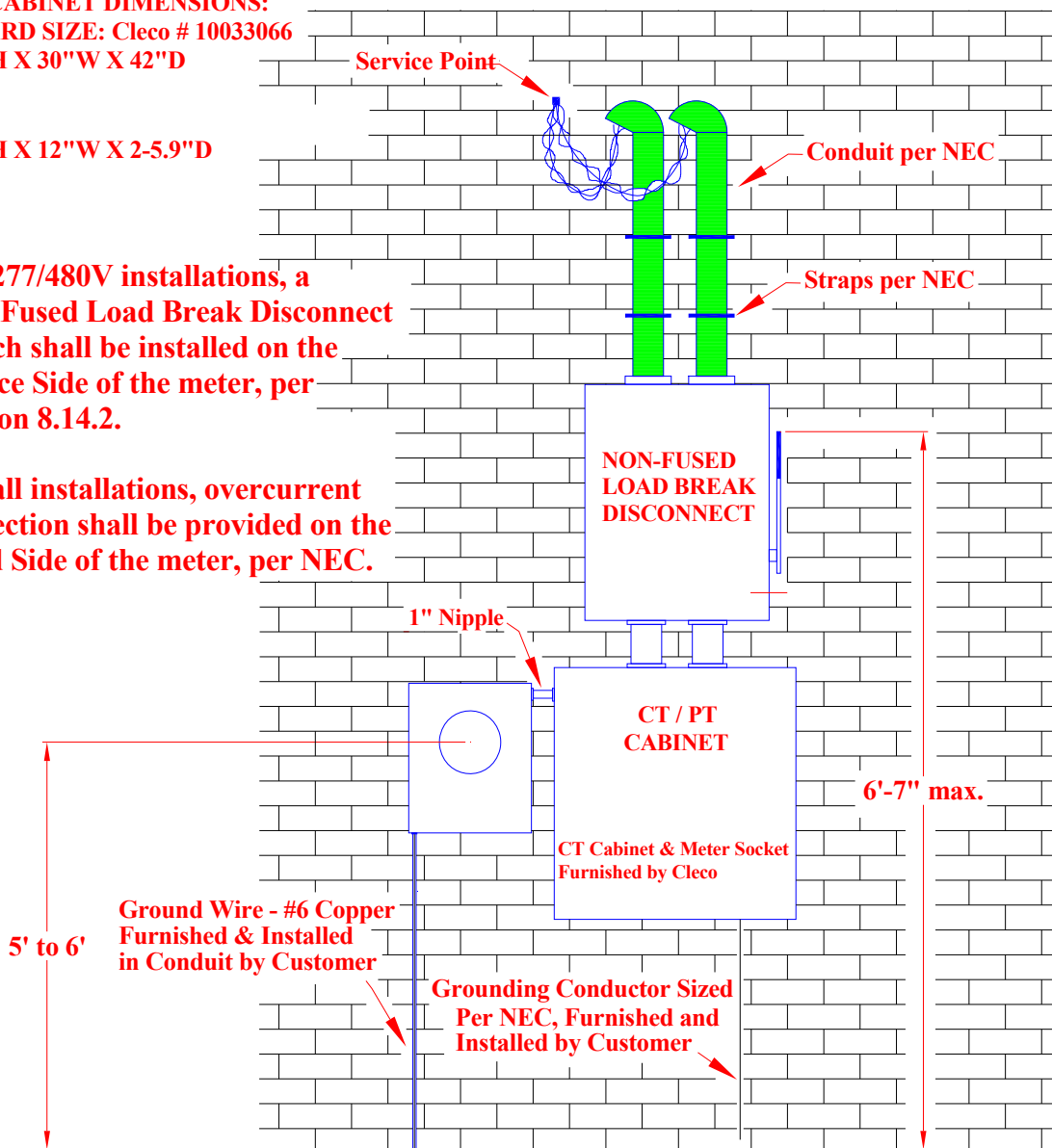

DRAWN BY:	trh	DATE:	4/21/15
REVISION:	11/18/19	REV BY:	MLM

CT OVERHEAD SERVICE
3-PHASE, 4-WIRE, 277/480 VOLT

FILE NAME:	IV-9
SCALE:	
SH. ___ OF	
___ SHEETS	

ELECTRIC SERVICE STANDARDS

Cleco Corporation
 PINEVILLE, LOUISIANA

Fig. IV-9 CT OH Service 277/480 Volts, Larger than 600 Amps

CT UNDERGROUND SERVICE ENTRANCE

3-PHASE, 4-WIRE 277/480 VOLTS, LARGER THAN 600 AMPS

**CT/PT CABINET DIMENSIONS:
STANDARD SIZE: Cleco # 10033066
11"H X 30"W X 42"D**

**SOCKET (13 TERMINAL Cleco # 10033081)
20"H X 12"W X 2-5.9"D**

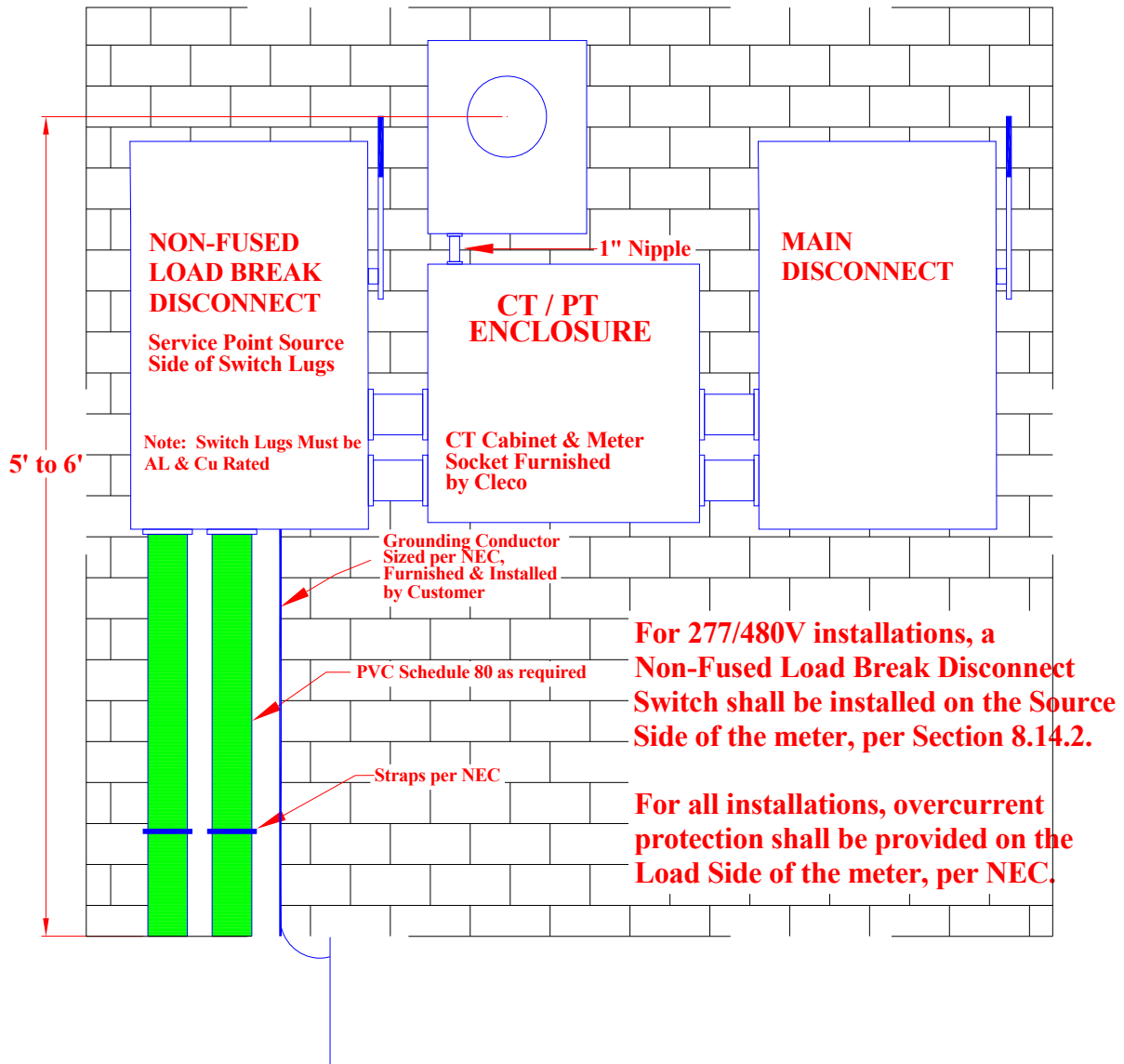

DRAWN BY:	trh	DATE:	11/19/04	CT UNDERGROUND SERVICE 3-PHASE, 4-WIRE 277/480 VOLT	FILE NAME:	IV-10
REVISION:	11/18/19	REV BY:	MLM		SCALE:	SH. ___ OF ___ SHEETS
ELECTRIC SERVICE STANDARDS				Cleco Corporation PINEVILLE, LOUISIANA		

Fig. IV-10 CT UG Service 277/480 Volts, Larger than 600 Amps

ELECTRIC SERVICE STANDARDS

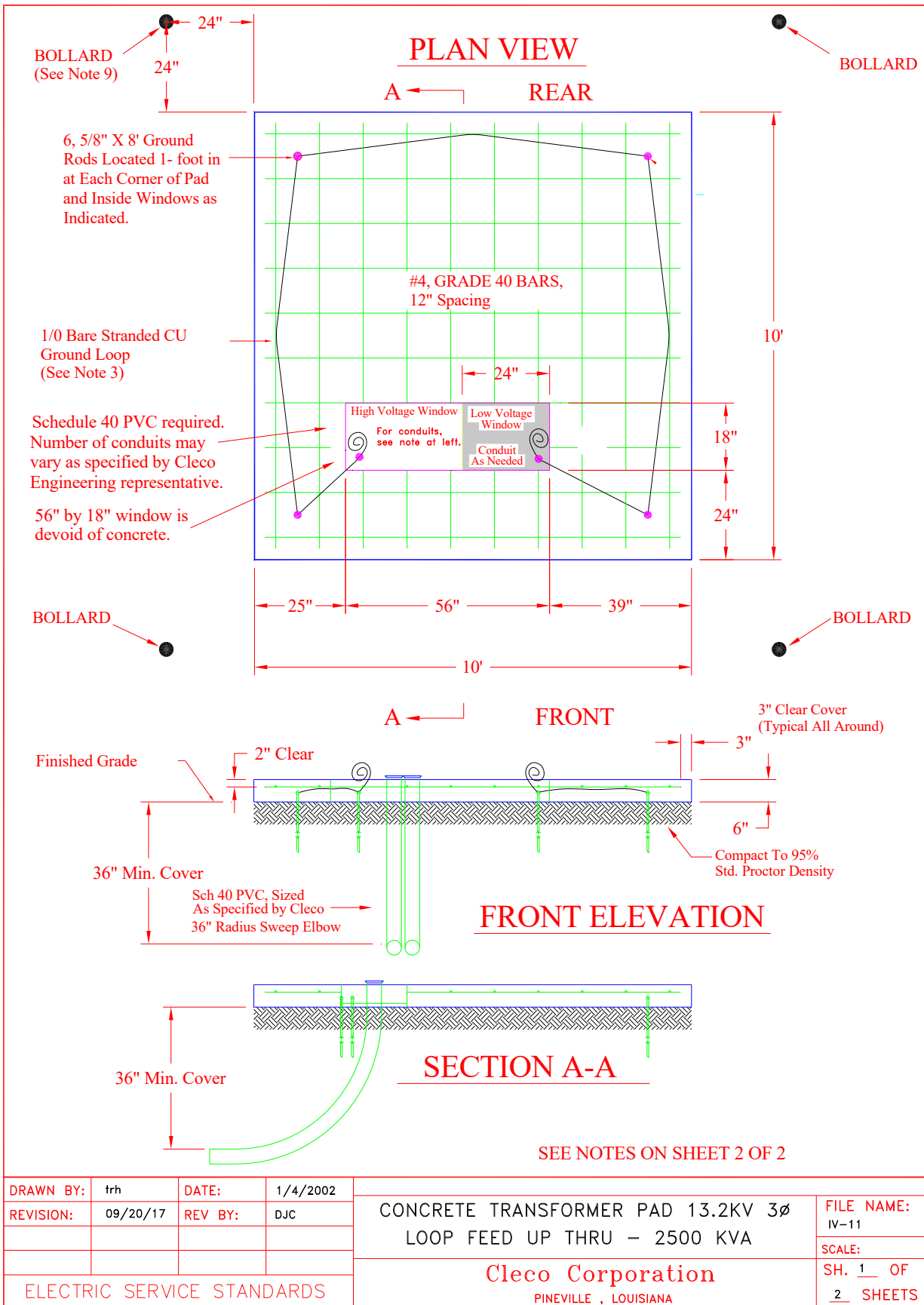

Fig. IV-11 Concrete XFM Pad 13.2KV 3-Phase Up thru 2500KVA

NOTES

1. THE SECTIONS OF CONDUIT FOR CLECO'S PRIMARY CONDUCTORS ARE TO BE POSITIONED IN THE HIGH VOLTAGE WINDOW OPENING AS SPECIFIED BY THE LOCAL CLECO ENGINEERING REPRESENTATIVE. THE PRIMARY CONDUIT SHALL UTILIZE 36" RADIUS SWEEP ELBOWS.
2. CONDUIT FOR SERVICE CONDUCTORS SHOULD BE POSITIONED AS REQUIRED IN THE 24" BY 18" LOW VOLTAGE WINDOW OPENING REPRESENTED BY THE SHADED AREA ON THE DRAWING. IF CLECO IS RESPONSIBLE FOR THE SERVICE CONDUCTORS REFER TO THE FOLLOWING CHART FOR DETERMINING THE MINIMUM RADIUS ELBOWS THAT CAN BE USED BASED ON THE SIZE CONDUIT SPECIFIED BY THE LOCAL CLECO ENGINEERING REPRESENTATIVE:

CONDUIT SIZE	MIN. BEND RADIUS
2"-2.5"	24"
3"-5"	36"
6"-8"	48"

3. GROUND LOOP CONDUCTOR IS TO BE CONTINUOUS WITH 3' TAILS EXPOSED ABOVE THE SLAB. INTERWEAVE THE GROUND CONDUCTOR WITH THE RE-BARS.
4. HAVE A CLECO REPRESENTATIVE INSPECT AFTER FORMING BUT BEFORE POURING THE SLAB.
5. ALL CONCRETE SHALL BE A MINIMUM 28 DAY COMPRESSIVE STRENGTH OF 3,000 PSI.
6. PROVIDE A MINIMUM OF TEN FEET CLEAR SPACE BETWEEN THE SIDES AND REAR OF THE CONCRETE PAD AND ANY STRUCTURE OPENING OR STRUCTURES NOT HAVING A THREE HOUR FIRE RATING.
7. PROVIDE A MINIMUM OF FIVE FOOT CLEAR SPACE BETWEEN THE SIDES AND REAR OF CONCRETE PAD AND ANY FENCE OR STRUCTURE HAVING A THREE HOUR FIRE RATING.
8. PROVIDE A MINIMUM OF FIFTEEN FEET OF CLEAR SPACE ON THE FRONT SIDE OF THE PAD SO CLECO PERSONNEL CAN INSTALL, OPERATE, AND MAINTAIN THE TRANSFORMER FROM THE FRONT OF THE PAD.
9. WHEN THE PAD IS IN AN AREA EXPOSED TO VEHICULAR TRAFFIC, PROVIDE FOUR, SIX INCH CONCRETE FILLED STEEL PIPE BOLLARDS LOCATED AS SHOWN ON THE DRAWING. BOLLARDS ARE TO BE TEN FEET IN TOTAL LENGTH WITH A SIX FEET BURIAL DEPTH.

DRAWN BY:	TRH	DATE:	1/4/2002	CONCRETE TRANSFORMER PAD 13.2KV 3Ø LOOP FEED UP THRU - 2500 KVA	FILE NAME:
REVISION:	09/20/17	REV BY:	DJC		IV-11A
					SCALE:
ELECTRIC SERVICE STANDARDS				Cleco Corporation PINEVILLE , LOUISIANA	SH. <u>2</u> OF <u>2</u> SHEETS

Fig. IV-11A Concrete XFM Pad 13.2KV 3-Phase Up thru 2500KVA

ELECTRIC SERVICE STANDARDS

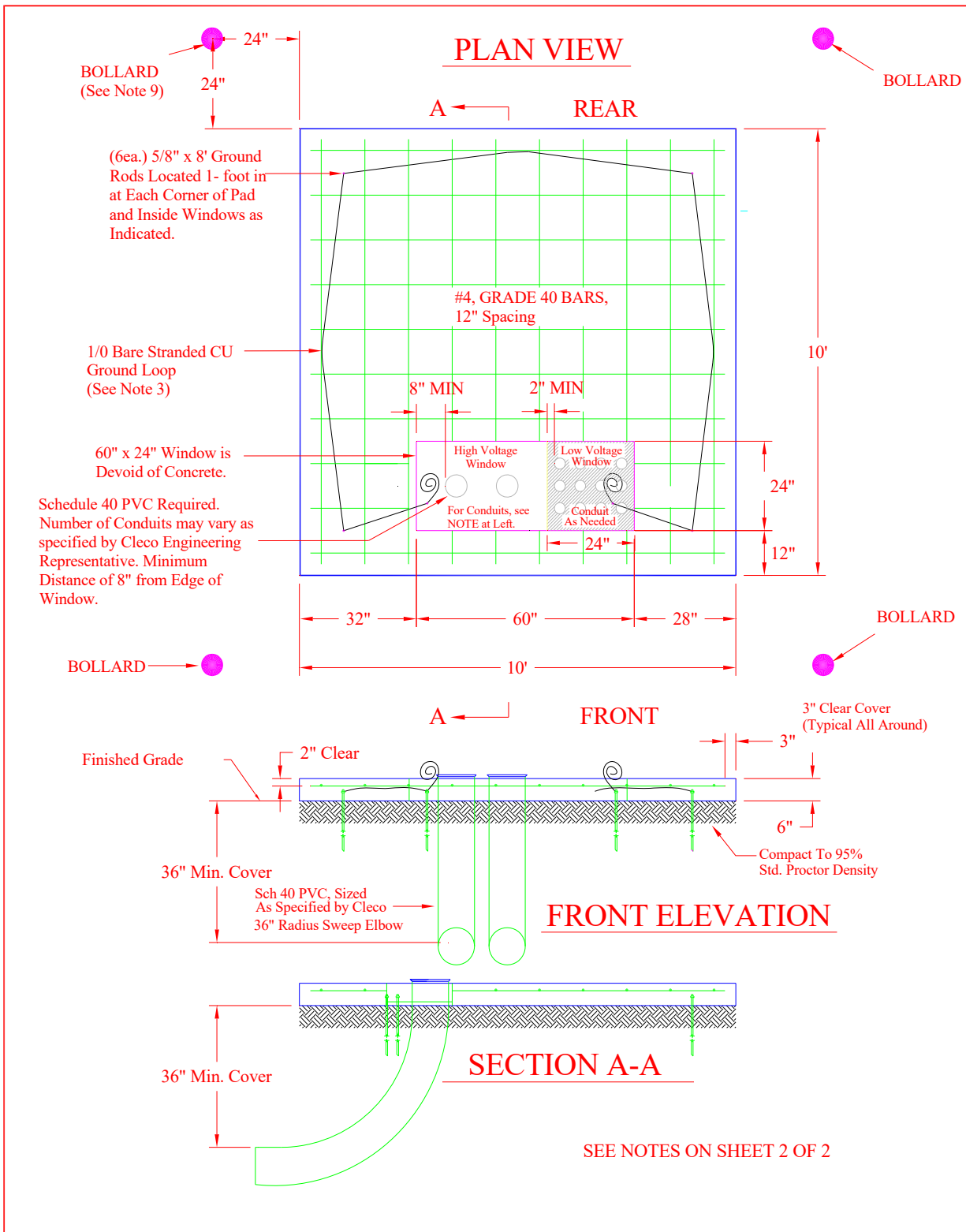

DRAWN BY:	trh	DATE:	1/4/2002	CONCRETE TRANSFORMER PAD 35KV 3ϕ LOOP FEED UP THRU 2500 KVA	FILE NAME:
REVISION:	10/13/17	REV BY:	DJC		IV-13
					SCALE:
ELECTRIC SERVICE STANDARDS				Cleco Corporation PINEVILLE, LOUISIANA	SH. <u>1</u> OF <u>2</u> SHEETS

Fig. IV-13 Concrete XFM Pad 35KV 3-Phase Up thru 2500KVA

NOTES

1. THE SECTIONS OF CONDUIT FOR CLECO'S PRIMARY CONDUCTORS ARE TO BE POSITIONED IN THE HIGH VOLTAGE WINDOW OPENING AS SPECIFIED BY THE LOCAL CLECO ENGINEERING REPRESENTATIVE.
2. CONDUITS FOR THE SECONDARY CONDUCTORS ARE TO BE POSITIONED AS REQUIRED IN 24" BY 24" LOW VOLTAGE WINDOW OPENING REPRESENTED BY THE SHADED AREA.
3. GROUND LOOP CONDUCTOR IS TO BE CONTINUOUS WITH 3' TAILS EXPOSED ABOVE SLAB. INTERWEAVE GROUND CONDUCTOR WITH RE-BARS.
4. HAVE CLECO INSPECT AFTER FORMING BUT BEFORE POURING.
5. ALL CONCRETE SHALL BE A MINIMUM 28 DAY COMPRESSIVE STRENGTH OF 3,000 PSI.
6. PROVIDE A MINIMUM OF TEN FEET CLEAR SPACE BETWEEN SIDES AND REAR OF CONCRETE PAD AND ANY STRUCTURE OPENING OR STRUCTURES NOT HAVING THREE HOUR FIRE RATED CONSTRUCTION.
7. PROVIDE A MINIMUM OF FIVE FOOT CLEAR SPACE BETWEEN SIDES AND REAR OF CONCRETE PAD AND ANY FENCE OR STRUCTURE HAVING THREE HOUR FIRE RATED CONSTRUCTION.
8. PROVIDE A MINIMUM OF FIFTEEN FEET OF CLEAR SPACE ON THE FRONT SIDE OF THE PAD SO THAT CLECO PERSONNEL CAN INSTALL, OPERATE, AND MAINTAIN THE TRANSFORMER FROM THE FRONT OF THE CONCRETE PAD.
9. PROVIDE FOUR, SIX INCH, CONCRETE FILLED, STEEL PIPE BOLLARDS, WHEN PAD IS IN AN AREA EXPOSED TO VEHICLES TRAFFIC. BOLLARDS ARE TO BE 10 FOOT IN TOTAL LENGTH WITH 6 FOOT BURIAL DEPTH.

DRAWN BY:	trh	DATE:	1/4/2002	CONCRETE TRANSFORMER PAD 35KV 3 ϕ LOOP FEED UP THRU 2500 KVA	FILE NAME:
REVISION:	10/13/17	REV BY:	DJC		IV-13A
				Cleco Corporation	SCALE:
ELECTRIC SERVICE STANDARDS				PINEVILLE , LOUISIANA	SH. <u>2</u> OF <u>2</u> SHEETS

Fig. IV-13A Concrete XFM Pad 35KV 3-Phase Up thru 2500KVA

APPENDIX V

MULTIPLE OCCUPANCY STRUCTURES

ELECTRIC SERVICE STANDARDS

This Page Left Blank Intentionally

ELECTRIC SERVICE STANDARDS

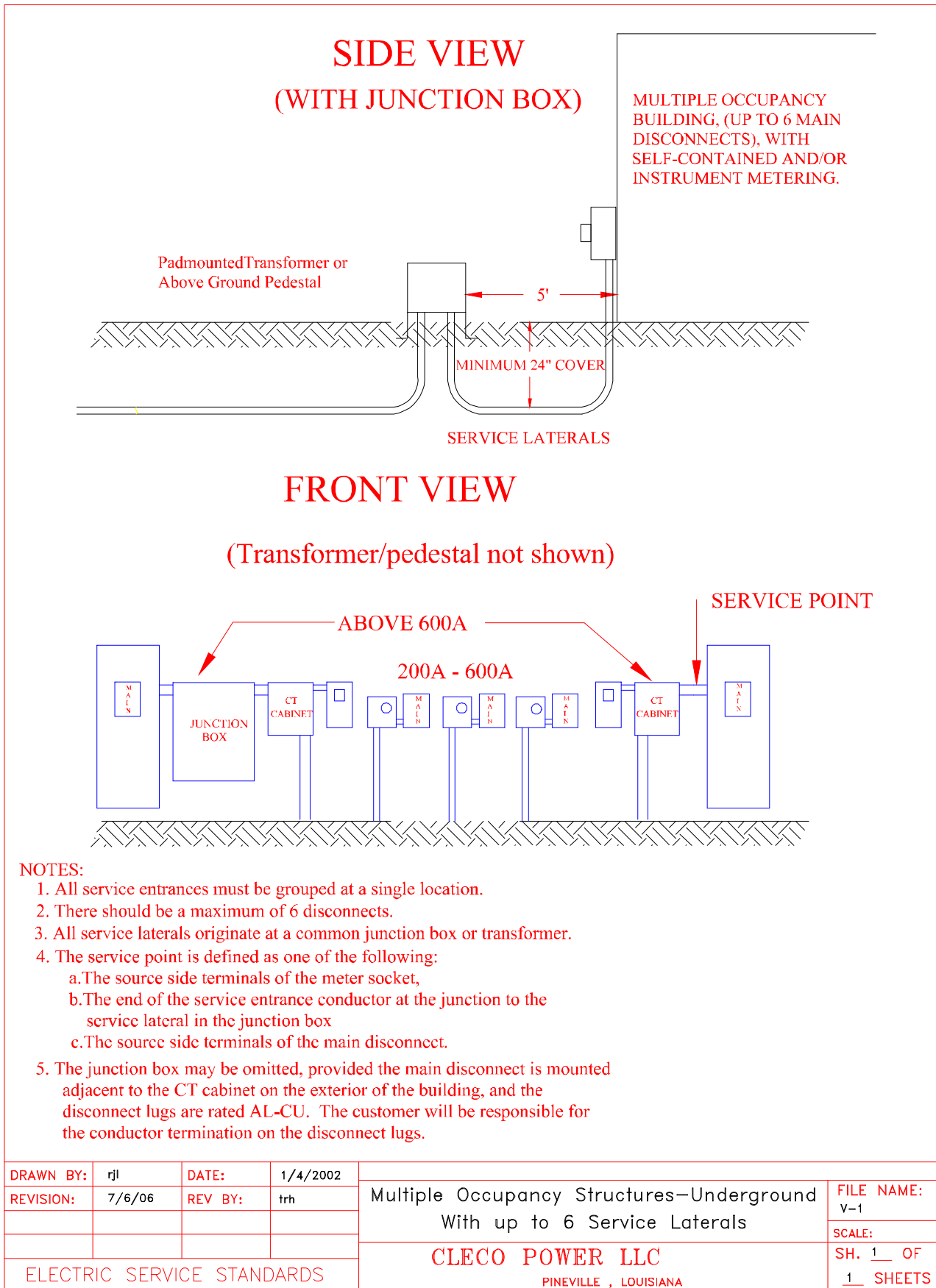

Fig. V- 1 Multiple Occupancy: UG; up to 6 Service Laterals

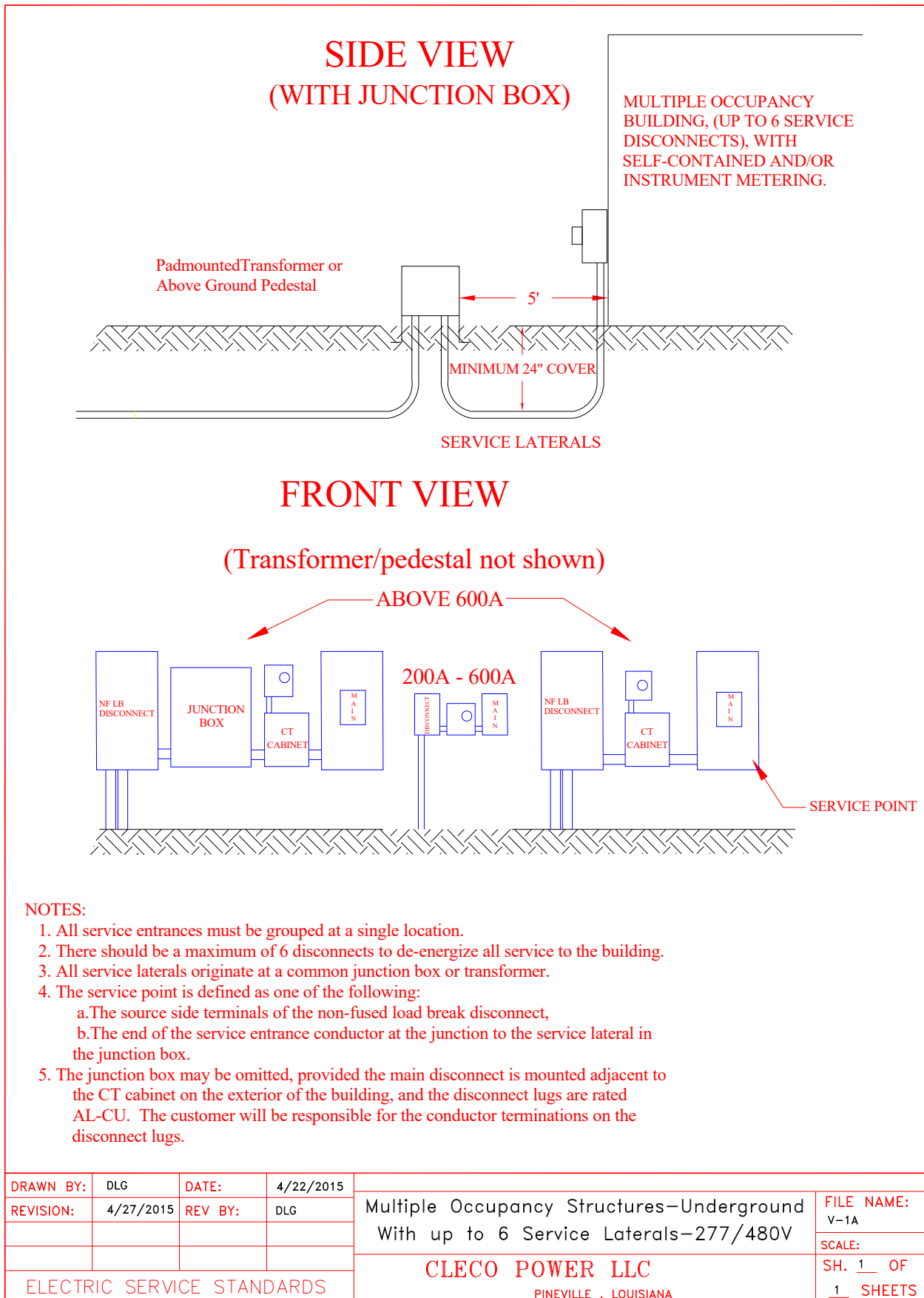
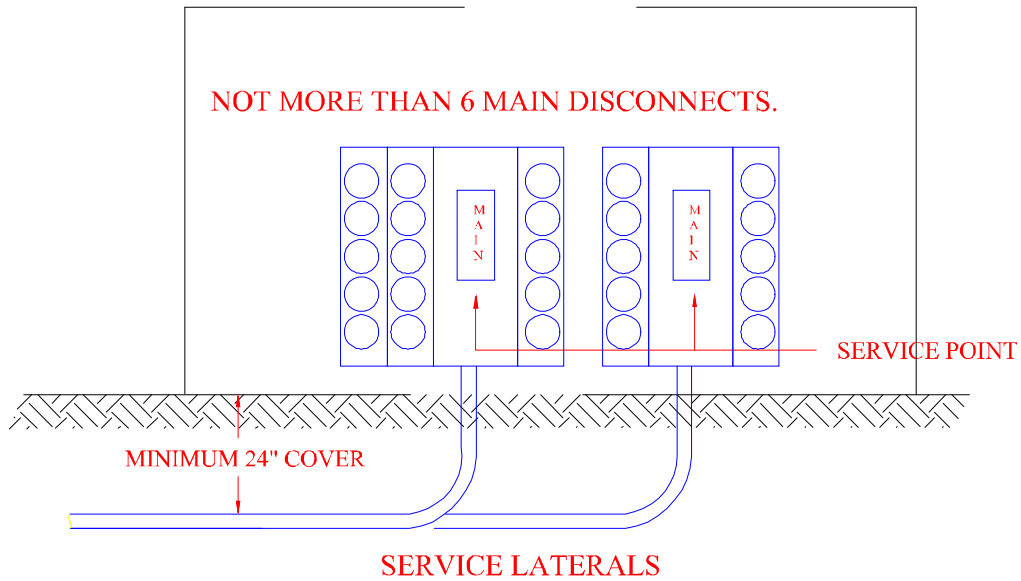

Fig. V- 1A Multiple Occupancy: UG; up to 6 Service Laterals-277/480

ELECTRIC SERVICE STANDARDS

MULTIPLE OCCUPANCY BUILDING UTILIZING METER CENTERS W/MAINS GROUPED.



NOTE: THE SERVICE POINT IS THE SOURCE-SIDE TERMINATION OF THE SERVICE LATERAL CONDUCTORS ON THE MAIN DISCONNECT. THE CUSTOMER WILL BE RESPONSIBLE FOR THE SERVICE LATERAL CONDUCTOR TERMINATION ON THE DISCONNECT.

DRAWN BY:	rjl	DATE:	1/4/2002	Multiple Occupancy Structures-UG Utilizing Meter Centers with Mains Grouped	FILE NAME:
REVISION:	7/28/06	REV BY:	trh		V-2
				Cleco Power LLC PINEVILLE , LOUISIANA	SCALE:
ELECTRIC SERVICE STANDARDS					SH. <u>1</u> OF <u>1</u> SHEETS

Fig. V-2 Multiple Occupancy: UG Utilizing Meter Centers w/ Mains Grouped

FRONT VIEW

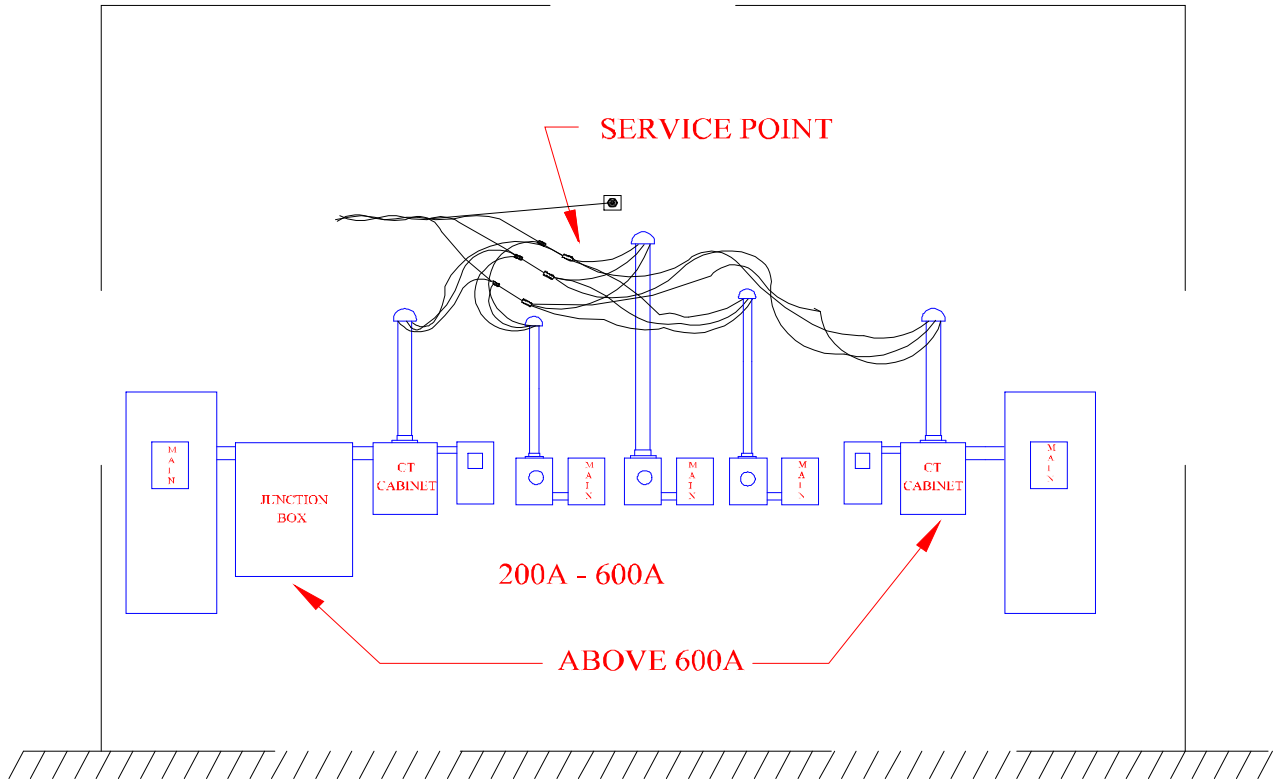

NOTES:

1. All service entrances must be grouped at a single location.
2. There should be a maximum of 6 disconnects.
3. The service point is defined as
The point of connection of the company's service drop conductors and the customer's service entrance conductors.
4. The junction box may be omitted, provided the main disconnect is mounted adjacent to the CT cabinet on the exterior of the building, and the disconnect lugs are rated AL-CU. The customer will be responsible for the conductor termination on the disconnect lugs.

DRAWN BY:	rjl	DATE:	1/4/2002	Multiple Occupancy Structures—Overhead With up to 6 Services	FILE NAME:
REVISION:	5/24/02	REV BY:	cmj		V-3
					SCALE:
ELECTRIC SERVICE STANDARDS				Cleco Corporation PINEVILLE, LOUISIANA	SH. 1 OF 1 SHEETS

Fig. V-3 Multiple Occupancy: OH; up to 6 Service Laterals

FRONT VIEW

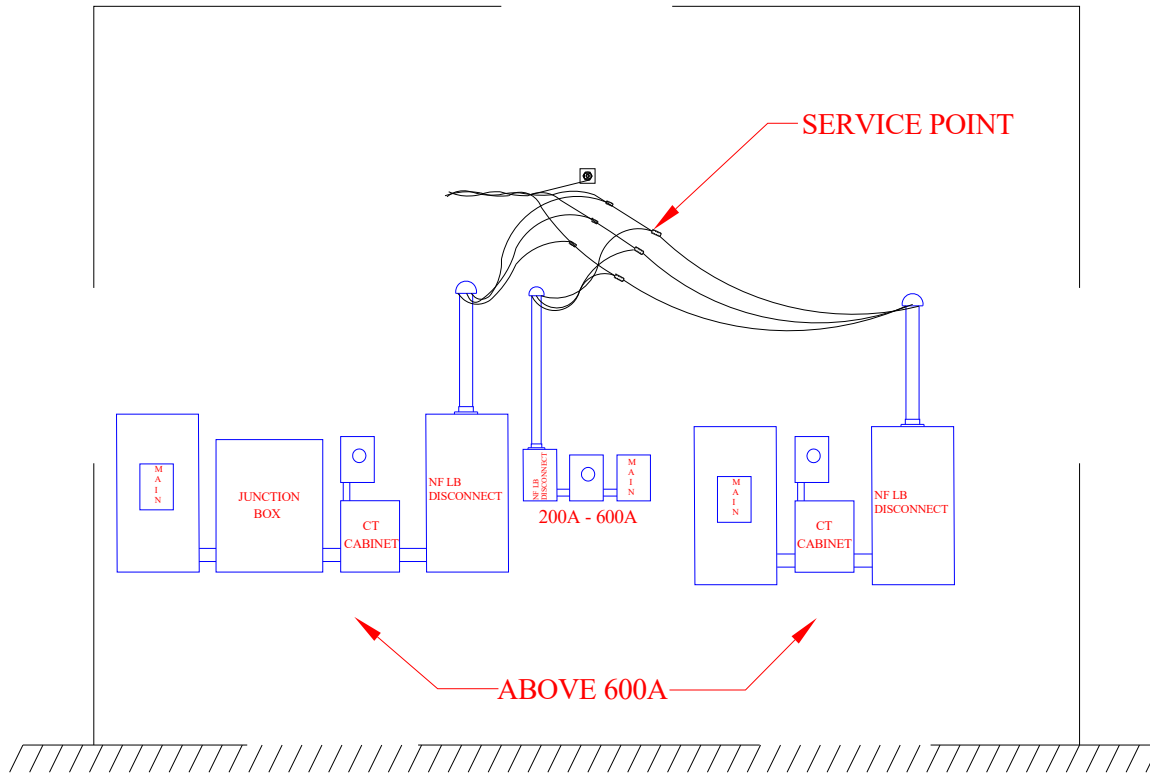

NOTES:

1. All service entrances must be grouped at a single location.
2. There should be a maximum of 6 disconnects to de-energize all service to the building.
3. The service point is defined as: The point of connection of the company's service drop conductors and the customers service entrance conductors.
4. The junction box may be omitted, provided the main disconnect is mounted adjacent to the CT cabinet on the exterior of the building, and the disconnect lugs are rated AL-CU. The customer will be responsible for the conductor terminations on the disconnect lugs.

DRAWN BY:	DLG	DATE:	5/5/2015	Multiple Occupancy Structures—Overhead With up to 6 Services—277/480V	FILE NAME:	V-3A
REVISION:		REV BY:			SCALE:	
ELECTRIC SERVICE STANDARDS				Cleco Corporation PINEVILLE , LOUISIANA	SH. <u>1</u> OF	<u>1</u> SHEETS

Fig. V- 3A Multiple Occupancy: OH; up to 6 Service Laterals-277/480V

ELECTRIC SERVICE STANDARDS

**MULTIPLE OCCUPANCY BUILDING
UTILIZING METER CENTERS W/MAINS GROUPED.**

NOT MORE THAN 6 MAIN DISCONNECTS.

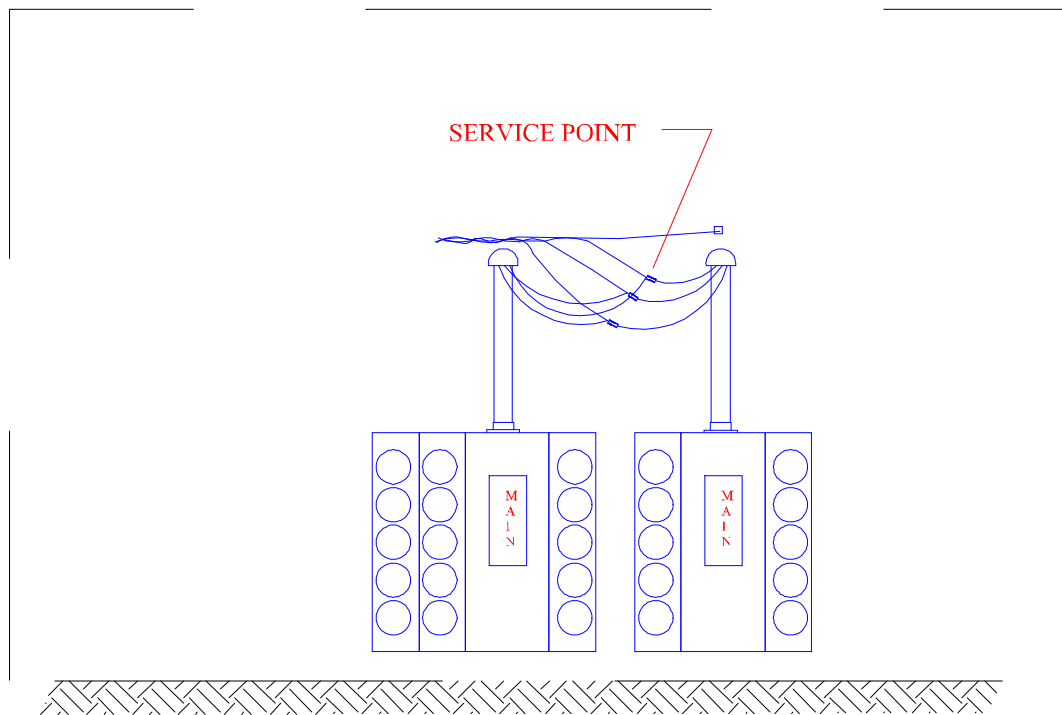

DRAWN BY:	rjl	DATE:	1/4/2002	Multiple Occupancy Structures—Overhead Utilizing Meter Centers with Mains Grouped	FILE NAME:
REVISION:	5/24/02	REV BY:	cmj		V-4
				Cleco Corporation PINEVILLE, LOUISIANA	SCALE:
ELECTRIC SERVICE STANDARDS					SH. <u>1</u> OF <u>1</u> SHEETS

Fig. V- 4 Multiple Occupancy: OH Utilizing Meter Centers w/ Mains Grouped

APPENDIX VI
LOAD INVENTORY FORMS

This Page Left Blank Intentionally



ELECTRIC SERVICE STANDARDS

ELECTRICAL LOAD INVENTORY

PROJECT NAME: _____
 PROJECT ADDRESS: _____
 TOWN: _____

LOAD SOURCE	KVA	OR	KW
LIGHTING		OR	
ELECTRICAL WATER HEATING		OR	
HEAT PUMP		OR	
SUPPLEMENTAL HEAT SYSTEM		OR	
AIR CONDITIONING		OR	
AIR HANDLING EQUIPMENT		OR	
ELECTRIC HEATING: (CIRCLE ONE) PRIMARY / SECONDARY		OR	
COOKING		OR	
REFIGERATION		OR	
RECEPTACLES: COMPUTER		OR	
OTHERS		OR	
MISCELLANEOUS		OR	
OTHER: (LIST)		OR	

TOTAL MOTOR LOAD (EXCLUDING HVAC) **

	OR	
--	----	--

**FOR MOTORS EXCEEDING 20 H.P.

LARGEST MOTOR SIZE: _____ H.P.
 SERVICE VOLTAGE: _____ VOLTS
 PHASE: (SINGLE OR THREE) _____ PHASE

BLDG. SQUARE FOOTAGE: _____ SQ. FT.

A/C OR HEAT PUMP TOTAL TONS: _____ TONS

SERVICE ENTRANCE SIZE: _____ AMPS

INFORMATION PROVIDED BY:

SITE PLAN OR SKETCH IS REQUIRED SHOWING PREFERRED METERING POINT

NAME: _____
 COMPANY NAME: _____
 PHONES: BUSINESS: _____
 MOBILE: _____
 FAX: _____
 BEEPER: _____

FORM 1: ELECTRICAL LOAD INVENTORY

PLEASE RETURN TO CLECO REPRESENTATIVE

This Page Left Blank Intentionally

ELECTRIC SERVICE STANDARDS

MOTOR INVENTORY

PROJECT NAME _____ (FOR MOTORS EXCEEDING 20 HP OR IF VOLTAGE RATING IS 2400 OR GREATER)

FUNCTION OF MOTOR <small>(MACHINERY DRIVEN BY MOTOR)</small>	NO. OF MOTORS	H.P.	TOTAL H.P.	FREQUENCY OF STARTS	NEMA CODE	LOCKED ROTOR CURRENT	FULL LOAD CURRENT

FORM 2: MOTOR INVENTORY